

# OPERATION & MAINTENANCE INSTRUCTIONS

Model Nos: GP100M, WP150, GP150M, GP200 -plus options

## STANDARD RANGE TRAILER MOUNTED PUMPSETS

PAGE 1 OF 87  
STATUS SHEET

### AMENDMENTS

ISSUE	DATE	TEXT AFFECTED
First	19 January 1998	First issue
Second	9 July 1998	Second issue
Third	12 October 1999	Third Issue
Fourth	February 2001	SP25 Vacuum Pump Added
Fifth	March 2001	GP200 x Iveco 8045E Added
Sixth	March 2003	Torque Flow Impellers
Seventh	September 2005	Coalescer secondary filter option.

**Andrews Sykes Hire Limited**

Premier House, Darlington Street, Wolverhampton WV1 4JJ

Telephone: 01902 328700

E-Mail: [info@andrews-sykes.com](mailto:info@andrews-sykes.com)

Fax: 01902 422466

web: [www.andrews-sykes.com](http://www.andrews-sykes.com)

<i>Sykes Pumps</i>	Ref.No.SY381-4	Issue Status: seventh
OPERATION& MAINTENANCE INSTRUCTIONS	Page 2 of 87	
STANDARD RANGE TRAILER MOUNTED PUMPS	Issued : 9 July	

# 1 CONTENTS

---

1	CONTENTS	2
1.1	List of Illustrations	4
1.2	List of Tables	5
2	FOREWORD	6
3	SERVICING AND REPAIR INFORMATION	7
3.1	Contacting your local Sykes depot	7
3.2	Ordering spares	7
4	SAFETY PRECAUTIONS	8
4.1	Warnings and Cautions	8
4.2	Training	8
5	DESCRIPTION OF EQUIPMENT	9
5.1	General description	9
5.2	Technical description	9
5.2.1	Overview	9
5.2.2	Main pump	11
5.2.3	Vacuum Pump	12
5.2.4	Engine, drives and fuel system	13
5.2.5		14
5.2.6	Chassis	15
5.3	Product Identification	16
6	HANDLING AND OPERATION	17
6.1	Lifting and transportation	17
6.2	Care and storage	17
6.3	Trailer routine checks	17
6.4	Siting and preparation for pumping	17
6.5	Controls and connection points	18
6.5.1	Main control panel	18
6.6	Operating instructions	19
6.6.1	General precautions	19
6.6.2	Starting up	19
6.6.3	Shutting down	20
6.7	Testing	21
6.7.1	Pump performance fault diagnosis	22
6.7.2	Priming system fault diagnosis	23

<i>Sykes Pumps</i>	Ref.No.SY381-4	Issue Status: seventh
OPERATION& MAINTENANCE INSTRUCTIONS	Page 3 of 87	
STANDARD RANGE TRAILER MOUNTED PUMPS	Issued : 9 July	

7	MAINTENANCE	24
	7.1 Tools required	24
	7.2 Maintenance schedule	24
	7.3 General instructions and precautions	26
	7.4 Engine and fuel system	26
	7.4.1 General	26
	7.4.2 Cleaning the fuel tank	26
	7.5 Vacuum pump drive belt	27
	7.5.1 Adjusting belt tension	27
	7.5.2 Renewing the belt	28
	7.6 Coalescer oil feed and filters	28
	7.7 Coalescer	28
	7.8 Priming tank air filter, surge control valve and air valve	29
	7.9 Vacuum pump	31
	7.9.1 Removing the vacuum pump	31
	7.9.2 Dismantling the vacuum pump	32
	7.9.3 Reassembling the vacuum pump	33
	7.9.4 Refitting vacuum pump	34
	7.10 Non-return valve	35
	7.11 Greasing the main pump bearings	35
	7.12 Main pump impeller and wear plates	35
	7.13 Main pump pressure seal	36
	7.13.1 Removing and refitting pump pressure seal	36
	7.13.2 Renewing the pump pressure seal packing	36
	7.14 Dismantling the drive	37
	7.14.1 Tyre coupling	37
	7.14.2 Flywheel coupling installation	38
	7.15 Main pump shaft and bearings	39
	7.15.1 Dismantling the shaft and bearings	40
	7.15.2 Renewing/re-fitting the bearings	40
	7.15.3 Fitting the bearing frame	40
	7.15.4 Fitting the impeller and setting wear plate clearances	41
8	SPARE PARTS	42
	8.1 Introduction	42
	8.2 Ordering Spares	42
9	APPENDICES	86
	9.1 Associated Publications	86

<i>Sykes Pumps</i>	Ref.No.SY381-4	Issue Status: seventh
OPERATION& MAINTENANCE INSTRUCTIONS	Page 4 of 87	
STANDARD RANGE TRAILER MOUNTED PUMPS	Issued : 9 July	

## 1.1 List of Illustrations

<b>Figure 1</b> Schematic of flow around the pumpset	10
<b>Figure 2</b> Main panel for electric start Lister TR engines, only	18
<b>Figure 3</b> Pump fault diagnosis flowchart	22
<b>Figure 4</b> Priming fault diagnosis chart	23
<b>Figure 5</b> Vacuum pump pulley arrangement	27
<b>Figure 6</b> Belt alignment	28
<b>Figure 7</b> Coalescer filter removal	29
<b>Figure 8</b> Vacuum priming tank	30
<b>Figure 9</b> Priming tank air and surge control valves	31
<b>Figure 10</b> - Taper Lock® screw positions	32
<b>Figure 11</b> - vacuum pump rotor	32
<b>Figure 12</b> Non-return valve	35
<b>Figure 13</b> Tyre coupling assembly	37
<b>Figure 14</b> Flywheel coupling	38
<b>Figure 15</b> 213W (element size) only	39
<b>Figure 16</b> Shaft alignment	39
<b>Figure 17</b> G.A. of two wheel site trailer	45
<b>Figure 18</b> G.A. of 4-Wheel Site Trailer	48
<b>Figure 19</b> GP200 Only	48
<b>Figure 20</b> G.A. 2-Wheel High Speed Trailer	51
<b>Figure 21</b> Bearing/Shaft Assembly - WP150 & GP100M	53
<b>Figure 22</b> Bearing/Shaft Assembly - GP150M & GP200	55
<b>Figure 23</b> Pressure Seal Assembly	57
<b>Figure 24</b> Impeller/Wear Plate Assembly - WP150 & GP100M	59
<b>Figure 25</b> Impeller/Wear Plate Assembly - GP150M & GP200	61
<b>Figure 26</b> Non Return Valve Assembly	63
<b>Figure 27</b> - Vacuum Pump - Drives and Fittings	65
<b>Figure 28</b> FL 25cfm Vacuum Priming System	67
<b>Figure 29</b> SP25 cfm Vacuum Priming System	67
<b>Figure 30</b> FL60 Vacuum Priming Pump	69
<b>Figure 31</b> SP60 Vacuum Priming Pump	69
<b>Figure 32</b> 25cfm Priming Tank Assembly	71
<b>Figure 33</b> 60 cfm priming tank	73
<b>Figure 34</b> Coalescer spare parts	75
<b>Figure 35</b> Two wheel site trailer	77
<b>Figure 36</b> Four wheel site trailer	79
<b>Figure 37</b> Two wheel high speed trailer	81
<b>Figure 38</b> 10/25 CFM Sump/Tee piece & Fittings Assembly	83
<b>Figure 39</b> 60 CFM Sump/Tee piece & Fittings Assembly	83
<b>Figure 40</b> Large volume sump-tee	85

<i>Sykes Pumps</i>	Ref.No.SY381-4	Issue Status: seventh
OPERATION& MAINTENANCE INSTRUCTIONS	Page 5 of 87	
STANDARD RANGE TRAILER MOUNTED PUMPS	Issued : 9 July	

## 1.2 List of Tables

<b>Table 1</b> Main pump technical data	11
<b>Table 2</b> Vacuum system technical data	12
<b>Table 3</b> Engine and fuel system technical data	13
<b>Table 4</b> Approximate component and combined weights	14
<b>Table 5</b> Chassis technical data	15
<b>Table 6</b> Vacuum pump clearance and dimensions	33
<b>Table 7</b> Clamping Screw Coupling Torque and Flange Spacing 'M	37
<b>Table 8</b> Coupling gap setting	37
<b>Table 9</b> - Flywheel settings	39
<b>Table 10</b> Impeller clearances	41

<i>Sykes Pumps</i>	Ref.No.SY381-4	Issue Status: seventh
OPERATION& MAINTENANCE INSTRUCTIONS	Page 6 of 87	
STANDARD RANGE TRAILER MOUNTED PUMPS	Issued : 9 July	

## 2 FOREWORD

---

This manual covers the Andrews Sykes STANDARD RANGE TRAILER-MOUNTED PUMPSETS. It is written for operators and maintenance personnel and provides the information needed for safe and efficient siting, use, testing, routine maintenance and repairs.

Manuals provided are an essential part of the relevant equipment. They should be kept for the life of the equipment and passed on to any subsequent purchaser. Any amendment issued by Andrews Sykes Hire Limited should be promptly incorporated into this manual.

Information contained in this manual is correct at the date of publication. As improvements are continually being made, Andrews Sykes Hire Limited reserve the right to make alterations without giving prior notice.

© 1998 Andrews Sykes Hire Limited. The contents of this manual are copyright and must not be reproduced without prior permission of Andrews Sykes Hire Limited.

Product names referenced in this manual are registered trade marks of the original equipment manufacturers.

### HEALTH & SAFETY STATEMENT

DO TAKE TIME TO ENSURE THAT YOUR SAFETY AND THAT OF OTHERS IS NOT PUT AT RISK. FAILURE TO OBSERVE PRECAUTIONS, BOTH ELEMENTARY AND THOSE EXPLICIT IN THIS MANUAL, MAY RESULT IN PERSONAL INJURY AND/OR DAMAGE TO EQUIPMENT. THE SAFETY INFORMATION ON PAGE 8 IS INTENDED TO MAKE YOU AWARE OF HAZARDS AND PRECAUTIONS AND TO ENCOURAGE A SAFETY-CONSCIOUS APPROACH TO OPERATING AND CARRYING OUT MAINTENANCE WORK ON THIS EQUIPMENT.

<i>Sykes Pumps</i>	Ref.No.SY381-4	Issue Status: seventh
OPERATION& MAINTENANCE INSTRUCTIONS	Page 7 of 87	
STANDARD RANGE TRAILER MOUNTED PUMPS	Issued : 9 July	

### **3      SERVICING AND REPAIR INFORMATION**

#### **3.1    Contacting your local Sykes depot**

For any enquiry regarding the use, servicing or repair of your Andrews Sykes pump, please contact your local Andrews Sykes Hire depot on (freefone) 0800-211-611.

Please provide the following information:

- (1)    Machine model and chassis type
- (2)    Model-Serial number of the machine
- (2)    Approximate date of purchase
- (3)    Details of enquiry, apparent fault(s), etc.

Section 5.3, *Product identification*, page 16 describes how to identify models and where to locate the Model-Serial number.

#### **3.2    Ordering spares**

Section 8, *Spare parts*, page 42, explains how to order spare parts.

<i>Sykes Pumps</i>	Ref.No.SY381-4	Issue Status: seventh
OPERATION& MAINTENANCE INSTRUCTIONS	Page 8 of 87	
STANDARD RANGE TRAILER MOUNTED PUMPS	Issued : 9 July	

## 4 SAFETY PRECAUTIONS

### 4.1 Warnings and Cautions

For the purpose of definition in this manual, a **WARNING** gives information which, if ignored, could engender serious injury to personnel. A **CAUTION** gives information which if ignored could cause serious damage to the machine or associated equipment.

#### WARNING

Warning notices are boxed and highlighted in the style of this paragraph.

#### CAUTION

Cautionary notices are boxed and highlighted in the style of this paragraph.

### 4.2 Training

It is strongly recommended that all operators, other personnel working on or near the pump, and any site visitors, are made fully aware of the potential dangers of this rotating equipment. If in **ANY** doubt please contact Andrews Sykes Limited Hire for advice.

#### WARNINGS

FOR YOUR OWN PERSONAL SAFETY READ AND TAKE NOTE OF THE FOLLOWING:

- |   |  |
|---|--|
| <b>Hazardous areas</b>                    | - All moving parts, including drive belts, are dangerous. All such moving parts are individually guarded and the pumpset <b>MUST</b> have all guarding in place during operation.<br><br>Pump intake and discharge ports are also dangerous when open. Do not insert hands or other objects into the ports when the pump is operating. |
| <b>Lifting and transport</b>              | - Read and follow the instructions on page 17. In particular, always lift using the lifting points provided and ensure that any lifting equipment is of adequate load-carrying capacity and possesses a valid test certificate.  |
| <b>Operating the pump</b>                 | - Note the general precautions on page 18 and ensure that you are familiar with the controls before operating the pump. Read and follow the instructions on safe siting and operation on pages 17 to 21.   |
| <b>Fault finding and pump maintenance</b> | - Follow a regular maintenance schedule as defined on page 24.   |



<i>Sykes Pumps</i>	Ref.No.SY381-4	Issue Status: seventh
OPERATION& MAINTENANCE INSTRUCTIONS	Page 9 of 87	
STANDARD RANGE TRAILER MOUNTED PUMPS	Issued : 9 July	

## 5 DESCRIPTION OF EQUIPMENT

---

### 5.1 General description

The GP is a range of general purpose, self priming, free standing site pumps. The pumps can be used in a range of environmental conditions, including tropical temperatures.

Each pump is capable of passing solids up to the specified maximum diameter for the size of machine (see **Table 1**, page 11), provided the solids are in suspension; a typical example being ditch water containing soil and rock particles. Slurries may also be pumped, if concentration of solid matter is not too high. The pumps can also handle abrasive materials at the expense of higher wear rate. (For advice on the suitability of your pump for specific applications contact your local Sykes depot; see Section 3.1, page 7.)

GP pumps are normally powered by a diesel engine with electric start. They are supplied on a four wheeled site trailer, two wheeled site trailer or two wheeled high speed road trailer chassis.

See CE certificate for applicable noise levels during operation.

### 5.2 Technical description

#### 5.2.1 Overview

This section identifies the main components of the standard pump and provides general technical and performance data. It does not cover any special options or modifications made to suit customer requirements.

---

 **NOTE:** Tolerances are given in Maintenance, Section 7 page 24.

---

 **NOTE:** By adjusting the 'surge control valve', when the pump is fully primed, the operator can prevent continual air valve cycling -an effect referred to as 'snoring' (See **Figure 8** and **Figure 9**).

---

**Figure 1** illustrates, schematically, the pumpset's principle of operation.

<b>Sykes Pumps</b>	Ref.No.SY381-4	Issue Status: seventh
OPERATION & MAINTENANCE INSTRUCTIONS	Page 10 of 87	
STANDARD RANGE TRAILER MOUNTED PUMPS	Issued : 9 July	

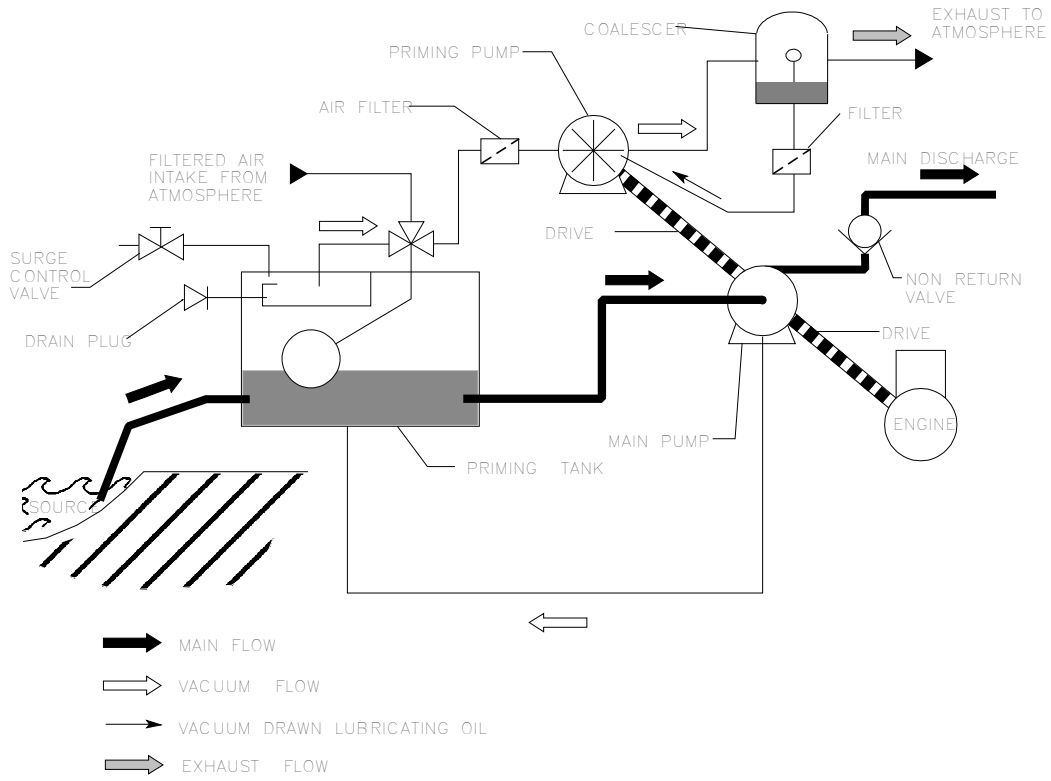

**Figure 1** Schematic of flow around the pumpset

<i>Sykes Pumps</i>	Ref.No.SY381-4	Issue Status: seventh
OPERATION& MAINTENANCE INSTRUCTIONS	Page 11 of 87	
STANDARD RANGE TRAILER MOUNTED PUMPS	Issued : 9 July	

### 5.2.2 Main pump

**Figure 21** to **Figure 25** show the main pump in detail.

**Table 1** Main pump technical data

PARAMETER	GP100M	WP150	GP150M	GP200
Standard pump body (volute) material	Cast iron	Cast iron	Cast iron	Cast iron
Volute size	100mm	100mm	150mm	150mm
Intake and discharge ports	100mm BSTD flange	150mm BSTD flange	150mm BSTD flange	200 BSTD flange
Solids handling capability (maximum diameter)	44mm	50mm	52mm	48mm
Maximum lift (theoretical)	10m	10m	10m	10m
Maximum discharge head	32m	38m	42m	65m
Maximum flow	160m <sup>3</sup> /hr	210m <sup>3</sup> /hr	320m <sup>3</sup> /hr	430m <sup>3</sup> /hr
Pump bearing grease	Shell Alvania EP2 or equivalent	Shell Alvania EP2 or equivalent	Shell Alvania EP2 or equivalent	Shell Alvania EP2 or equivalent
Nominal speed	1800 rpm	1800 rpm	1800 rpm	1800 rpm

<i>Sykes Pumps</i>	Ref.No.SY381-4	Issue Status: seventh
OPERATION& MAINTENANCE INSTRUCTIONS	Page 12 of 87	
STANDARD RANGE TRAILER MOUNTED PUMPS	Issued : 9 July	

### 5.2.3 Vacuum Pump

**Figures 30 to 33** show exploded views of the vacuum pumps. **Figure 29** shows it assembled onto the pump set.

**Table 2** Vacuum system technical data

COMPONENT/PARAMETER	25cfm	60cfm
Vacuum pump displacement	12 litres/s	28 litres/s
Vacuum level	9m	9m
Lubricating oil	30 SAE viscosity below 30°C 10W30 SAE above 30°C	30 SAE viscosity below 30°C 10W30 SAE above 30°C
Nominal speed	1550 rpm	1100 rpm

<i>Sykes Pumps</i>	Ref.No.SY381-4	Issue Status: seventh
OPERATION& MAINTENANCE INSTRUCTIONS	Page 13 of 87	
STANDARD RANGE TRAILER MOUNTED PUMPS	Issued : 9 July	

#### 5.2.4 Engine, drives and fuel system

**Table 3** Engine and fuel system technical data

COMPONENT/ PARAMETER	COMMENTS	SPECIFICATION			
		GP100M	WP150	GP150M	GP200M
Engine	Drives main and vacuum pumps	Lister TR2 air cooled diesel	Lister TS3 air cooled diesel	Lister TR3 air cooled diesel	Iveco 8045SE Turbo diesel
Main pump coupling	High misalignment tolerance and vibration isolation	Fennaflex tyre coupling	Fennaflex tyre coupling	Fennaflex tyre coupling	Fenner flywheel coupling
Vacuum pump transmission		Fenner toothed drive belt and pulleys	Fenner toothed drive belt and pulleys	Fenner toothed drive belt and pulleys	Fenner toothed drive belt and pulleys
Battery		12V 669 540 Ah	12V 669 540 Ah	12V 669 540 Ah	12V 643 103 Ah
Fuel tank		110 litres	110 litres	110 litres	150 litres
Approximate running time on full tank, at max load		29 hours	22 hrs	20 hrs	11 hrs
Nominal speed		1800 rpm	1800 rpm	1800 rpm	1800 rpm

<i>Sykes Pumps</i>	Ref.No.SY381-4	Issue Status: seventh
OPERATION& MAINTENANCE INSTRUCTIONS	Page 14 of 87	
STANDARD RANGE TRAILER MOUNTED PUMPS	Issued : 9 July	

### 5.2.5 Weights

**Table 4** provides approximate component weights for the pumpset and its major components. The weights given are typical and may vary by  $\pm 20\%$  for individual machines. Therefore, ensure that all lifting and towing equipment used have a safe working load of at least 120% of the relevant indicated weight.

**Table 4** Approximate component and combined weights

COMPONENT	WEIGHT (kg)			
	GP100M	WP150	GP150M	GP200M
Engine	245	260	260	400
Main pump	300	450	525	605
Main pump, priming tank, engine and coupling	600	775	850	1065
Priming tank	30	45	45	45
Gross weight inc. chassis & full tank of fuel for 4-wheel site trailer	1000	1175	1250	1605
Gross weight inc. chassis & full tank of fuel for 2-wheel site trailer	950	1125	1200	—
Gross weight inc. chassis & full tank of fuel for 2-wheel high speed trailer	1200	1375	1450	----

<i>Sykes Pumps</i>	Ref.No.SY381-4	Issue Status: seventh
OPERATION& MAINTENANCE INSTRUCTIONS	Page 15 of 87	
STANDARD RANGE TRAILER MOUNTED PUMPS	Issued : 9 July	

## 5.2.6 Chassis

**Table 5** Chassis technical data

<b>COMPONENT/ PARAMETER</b>	<b>2-wheel site trailer</b>	<b>4-wheel site trailer</b>	<b>2-wheel high speed trailer</b>
General specification	Fixed towing arm	Rear fixed, front swivel arm	Beam axle suspension, A-frame fixed chassis
Maximum towing speed	Site limits apply (10-15 mph)	Site limits apply (10-15 mph)	Legal speed limit
Tyres	Pneumatic	Solid	Pneumatic road tyres
Tow-hitch details	Towing eye to suit vertical towing pin (max 50mm)	Towing eye to suit vertical towing pin (max 50mm)	50 mm dia. ball hitch, braked
Recommended lifting methods	Crane, using the single lifting point.	Crane, using the single lifting point.	Crane, using the single lifting point.

<b>Sykes Pumps</b>	Ref.No.SY381-4	Issue Status: seventh
OPERATION& MAINTENANCE INSTRUCTIONS	Page 16 of 87	
STANDARD RANGE TRAILER MOUNTED PUMPS	Issued : 9 July	

### 5.3 Product Identification

For your own security and to enable Andrews Sykes Hire Limited to answer any enquiries and requests for service and spares, where not stated, record details of your pumpset in the table below.

DETAIL	CORRESPONDING INFORMATION			
	GP100M		WP150	
Chassis Type	4WST	2HST	2WST	4WST
Serial Number	SY3811051	SY3811052	SY3821084	SY3821078
Serial Number Suffix				
Serial Number			SY3821084-2	SY3821079
Serial Number Suffix				
Variations From Standard			Hand-start Engine	Large Volume Sump Tee
Serial Number				
Serial Number Suffix				
Variations From Standard				
Engin Serial Number				
Date of Purchase				

DETAIL	CORRESPONDING INFORMATION				
	GP150M			GP200	
Chassis Type	2WST	4WST	2HST	4WST	2HST
Serial Number	SY3831075	SY3831067	SY3831068	SY3841036	SY3841069
Serial Number Suffix					
Serial Number		SY3831070	SY3831068-R	SY3841033	
Serial Number Suffix					
Variations From Standard		Large Volume Sump Tee	Anti-Ragging Impeller & Front Wear Plate	25 cfm Vacuum Drive Assembly	
Serial Number		SY3831065	SY3831069		
Serial Number Suffix					
Variations From Standard		25 cfm Vacuum Drive Assembly	25 cfm Vacuum Drive Assembly		
Engin Serial Number					
Date of Purchase					



<i>Sykes Pumps</i>	Ref.No.SY381-4	Issue Status: seventh
OPERATION& MAINTENANCE INSTRUCTIONS	Page 17 of 87	
STANDARD RANGE TRAILER MOUNTED PUMPS	Issued : 9 July	

## 6 HANDLING AND OPERATION

---

### 6.1 Lifting and transportation

All pumpset variants are equipped with the single point lifting eye by which they may be lifted using a suitable chain.

#### WARNINGS

**DO NOT** attempt to lift pump with suction and discharge hoses in place.

**ALWAYS** ensure that lifting gear are adequate for the weight being lifted (See **Table 4**).

The trailer may be towed behind a suitable vehicle. Check that the vehicle has a suitable towbar.

### 6.2 Care and storage

To maintain the body parts in good condition, it is strongly recommended that the trailer is steam or spray cleaned regularly to remove road dirt, mud and grit.

See Section 6.6.3 for shutting down procedure.

When not in use store the trailer under cover in a dry environment, where practicable.

### 6.3 Trailer routine checks

Routine checks are essential for personal safety and maintenance of equipment condition. (Consult **Table 5** for all chassis related technical data.)

### 6.4 Siting and preparation for pumping

If you wish to test pump operation before use, refer to *Testing*, page 21.

6.4.0.1 Place the pumpset on a firm, level area of ground, as close as practical to the source of liquid.

6.4.0.2 Connect the hoses to the intake and discharge flanges.

---

 **NOTE:** USE all the bolt holes provided on the flanges. **DO NOT** use a collapsible hose on the suction side, and make sure the strainer is in place on the suction side.

---

6.4.0.3 Submerge the end of the suction hose.

6.4.0.4 Place the end of the discharge hose in a suitable outlet.

<i>Sykes Pumps</i>	Ref.No.SY381-4	Issue Status: seventh
OPERATION& MAINTENANCE INSTRUCTIONS	Page 18 of 87	
STANDARD RANGE TRAILER MOUNTED PUMPS	Issued : 9 July	

**CAUTION**

**DO NOT** put any stress on hoses. Lay them so as to avoid forming sharp kinks and protect them where they come in contact with abrasive surfaces.

**6.5 Controls and connection points**

**6.5.1 Main control panel**

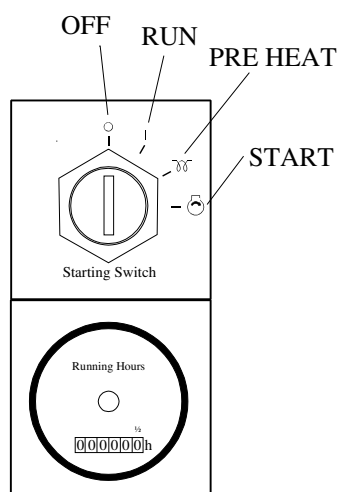

**Figure 2** Main panel for electric start Lister TR engines, only

<i>Sykes Pumps</i>	Ref.No.SY381-4	Issue Status: seventh
OPERATION& MAINTENANCE INSTRUCTIONS	Page 19 of 87	
STANDARD RANGE TRAILER MOUNTED PUMPS	Issued : 9 July	

## 6.6 Operating instructions

### 6.6.1 General precautions

#### WARNINGS

**DO NOT** attempt to insert anything into the pump intake and discharge ports while the engine is running.

Ensure the pumpset is stable and immobilised **BEFORE** starting the pump.

#### WARNINGS

**BEWARE** of fire risks. **DO NOT** place any flammable material near or around the engine or exhaust. Allow adequate ventilation.

The engine, exhaust and coalescer become **HOT** during operation.

**ENSURE** that any discharge into rivers or watercourses, or to soak away onto land, is environmentally acceptable.

The pump body retains liquid which could be hazardous to health. Flush the pump with clean water **BEFORE** disconnecting the hoses or working on the pump.

---

 **NOTE:** In the event of an emergency, **STOP** the engine **IMMEDIATELY** using the engine key on the main control pane .

---

#### CAUTIONS

**NEVER** use the pump without a strainer.

**DO NOT** pump, either liquids that may damage the pump, or dry material. If in doubt contact your local Andrews Sykes depot for advice (see Section 3.1, page 7).

### 6.6.2 Starting up

Follow this procedure before each engine start-up. Refer to Section 6.5, page 18, for details of controls.

#### WARNINGS

Make sure you are familiar with the engine manufacturer's safety instructions **BEFORE** running the engine.

<i>Sykes Pumps</i>	Ref.No.SY381-4	Issue Status: seventh
OPERATION& MAINTENANCE INSTRUCTIONS	Page 20 of 87	
STANDARD RANGE TRAILER MOUNTED PUMPS	Issued : 9 July	

### CAUTION

**ALWAYS** top up using oil of correct specification. See the manufacturer's handbook for details of engine oil, and **Table 2**, page 12, for details of vacuum pump oil.

6.6.2.1 Drain any water in the coalescer through the drain tap provided.

6.6.2.2 Check and top up, if necessary;

6.6.2.2.0.1 the engine fuel, oil and radiator water levels;

6.6.2.2.0.2 the oil level in the coalescer.

---

 **NOTE:** Oil surface should be just visible when looking into the filler strainer.

---

6.6.2.3 Ensure that all drain taps are closed.

6.6.2.4 Screw in fully the priming tank surge control valve, to allow the system to prime.

6.6.2.5 Submerge the suction hose in the source.

6.6.2.6 Refer to **Figure 2**. Turn the ignition key to **ON** position.

6.6.2.7 Turn the key to **WARM UP** position for 15 seconds.

6.6.2.8 Turn the key clockwise to the **START** position and release as soon as the engine starts.

If the engine fails to start within 30 seconds, release the key and attempt to restart after allowing time for all moving parts to come to rest.

(The pump should prime automatically. In case of start-up failure, consult *Fault diagnosis* on page 23.)

6.6.2.9 When the pump is fully primed, re-adjust the surge control valve, as necessary, to avoid 'snoring' -see page 9.

### 6.6.3 Shutting down

---

 **NOTE: TO STOP-** Turn the engine key to the **STOP** position and push in fully the surge control valve knob to release the vacuum and empty the the priming tank and the intake hose.

---

<i>Sykes Pumps</i>	Ref.No.SY381-4	Issue Status: seventh
OPERATION& MAINTENANCE INSTRUCTIONS	Page 21 of 87	
STANDARD RANGE TRAILER MOUNTED PUMPS	Issued : 9 July	

**CAUTION**

**ALWAYS** drain the pump; before removing it, or if it is being left unused for a while - especially in cold weather.

The procedure is as stated below.

6.6.3.1 Flush the pump with clean water.

6.6.3.2 Drain water from the following, through the drain taps or plugs provided;

- 6.6.3.2.0.1 the main pump;
- 6.6.3.2.0.2 the priming tank; and,
- 6.6.3.2.0.3 the non-return valve.
- 6.6.3.2.0.4 the coalescer

6.6.3.3 Follow the engine manufacturer's instructions relating to engine being left unused for a period of time.

If the pump is to be moved to a new site, disconnect the hoses and follow the instructions in Section 6.1, *Lifting and transportation*, page 17.

**CAUTION**

**NEVER** leave water in the pumps or hoses if there is any risk of it freezing.

## **6.7 Testing**

To test correct operation of the pumpset before its first service, or whenever required, follow the procedure described below.

6.7.0.1 Immobilise and secure the pumpset, at the test site.

6.7.0.2 Start the engine as described in Section 6.6.2, page 19, but leave the surge control valve fully screwed in throughout the test.

6.7.0.3 Place a 'cone tester' (or an alternative test gauge) in the inlet flange and check that the vacuum reading is sufficient for the intended lift plus the pipework losses. If the vacuum reading is unsatisfactory or the pump fails to prime consult *fault diagnosis*, Section 6.7.2, page 23.

6.7.0.4 Stop the engine.

<b>Sykes Pumps</b>	Ref.No.SY381-4	Issue Status: seventh
OPERATION& MAINTENANCE INSTRUCTIONS	Page 22 of 87	
STANDARD RANGE TRAILER MOUNTED PUMPS	Issued : 9 July	

### 6.7.1 Pump performance fault Diagnosis

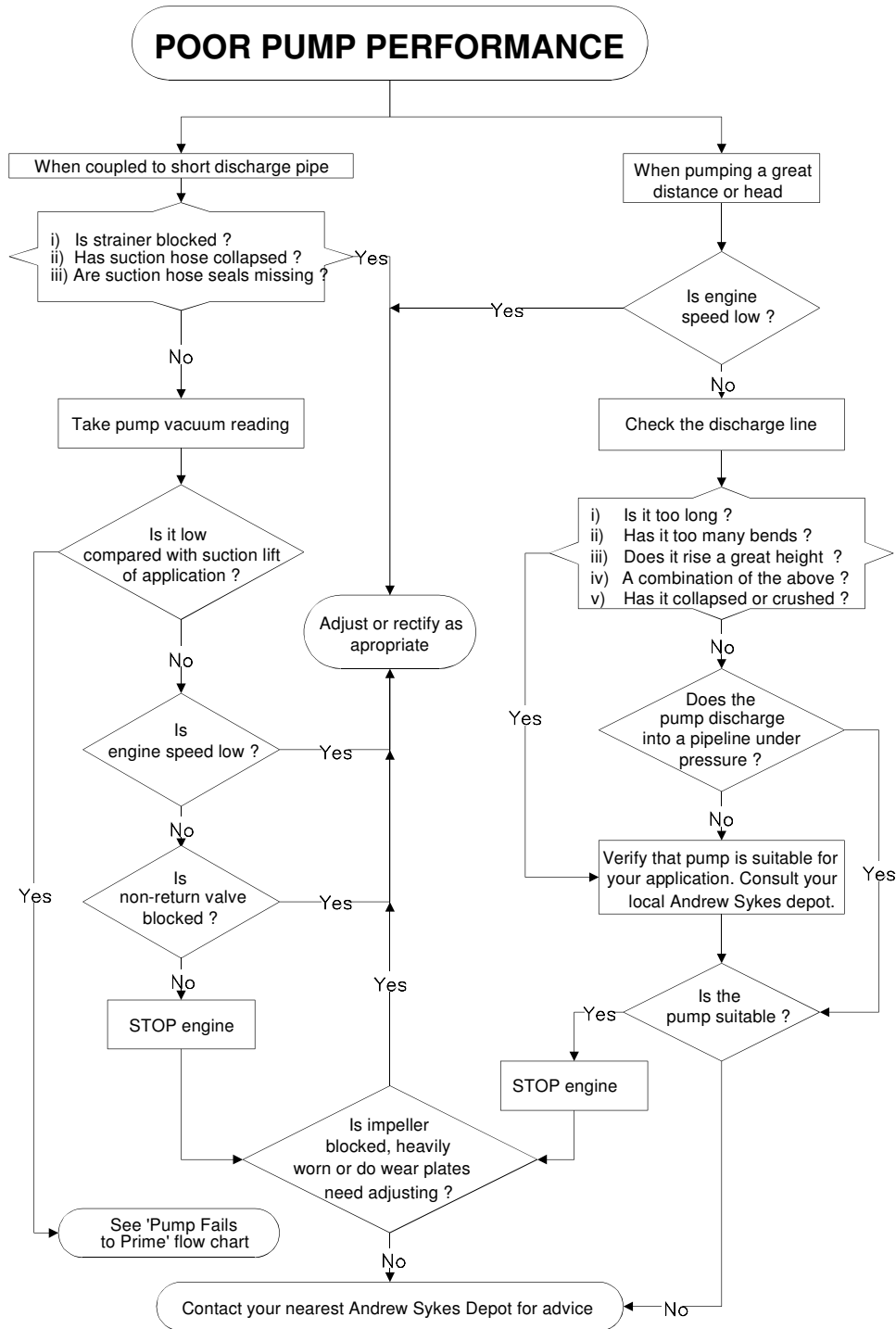

**Figure 3** Pump fault diagnosis flowchart

<i>Sykes Pumps</i>	Ref.No.SY381-4	Issue Status: seventh
OPERATION & MAINTENANCE INSTRUCTIONS	Page 23 of 87	
STANDARD RANGE TRAILER MOUNTED PUMPS	Issued : 9 July	

### 6.7.2 Priming system fault diagnosis



**Figure 4** Priming fault diagnosis chart

<i>Sykes Pumps</i>	Ref.No.SY381-4	Issue Status: seventh
OPERATION& MAINTENANCE INSTRUCTIONS	Page 24 of 87	
STANDARD RANGE TRAILER MOUNTED PUMPS	Issued : 9 July	

## 7 MAINTENANCE

---

### 7.1 Tools required

7.1.0.1 A standard fitters-toolkit.

### 7.2 Maintenance schedule

The following schedule provides a guide for maintaining the pump. The actual hours of operation between maintenance will depend on the operating conditions. For full details of engine maintenance, refer to the manufacturer's handbook.

Maintenance description	Refer to Section	Running hours					
		Daily	125	250	500	2000	6000
<b>Vacuum pump and priming system:</b>							
Drain water from coalescer	5.3	×					
Check coalescer oil level and top up if required	5.3	×					
Check tension and condition of vacuum pump drive belt	7.5			×			
Change vacuum pump oil and clean oil filters	7.6			×			
Check priming tank valves and clean or renew air filter	7.8				×		
Renew vacuum pump drive belt	7.5					×	
Check non-return valve ball is sealing on seat	7.10					×	
Dismantle and clean priming tank, valves and pipes	7.8					×	
Check performance of vacuum pump and overhaul as necessary	7.9					×	



<i>Sykes Pumps</i>	Ref.No.SY381-4	Issue Status: seventh
OPERATION& MAINTENANCE INSTRUCTIONS	Page 25 of 87	
STANDARD RANGE TRAILER MOUNTED PUMPS	Issued : 9 July	

Maintenance description	Refer to Section	Running hours					
		Daily	125	250	500	2000	6000
Clean coalescer filter	7.6						×
<b>Main pump:</b>							
Grease pump bearings	7.11			×	×		
Check impeller and wear plates for wear and renew or adjust as required.	7.12					×	
Renew pump pressure seal gland packing	7.13				×		
Check condition of main pump bearings	7.15						×

<i>Sykes Pumps</i>	Ref.No.SY381-4	Issue Status: seventh
OPERATION& MAINTENANCE INSTRUCTIONS	Page 26 of 87	
STANDARD RANGE TRAILER MOUNTED PUMPS	Issued : 9 July	

## 7.3 General instructions and precautions

### WARNINGS

**ALWAYS** ensure that slings, shackles etc. are adequate for the weight being lifted. (See **Table 4**, page 14.)

Chock and stabilise the chassis **BEFORE** commencing work.

### CAUTIONS

Drain main pump volute and priming tank.

**ALWAYS** remove major component to clean workshop conditions for overhaul.

- 7.3.0.1 Disconnect the wiring loom from the control panel.
- 7.3.0.2 Disconnect and remove the battery.
- 7.3.0.3 Disconnect the fuel hoses and from the engine.
- 7.3.0.4 Remove all guarding.
- 7.3.0.5 Disconnect the engine from its mounts and the pump bearing frame.
- 7.3.0.6 Disconnect the drive coupling.
- 7.3.0.7 Lift engine by its lifting points (Lifting gear will be required).
- 7.3.0.8 Disconnect the pump from its mounts.
- 7.3.0.9 Using suitable lifting straps, remove pump end assembly.

## 7.4 Engine and fuel system

### 7.4.1 General

Consult original manufacturer's handbook for engine maintenance instructions.

### 7.4.2 Cleaning the fuel tank

- 7.4.2.1 Remove the drain plugs and drain the fuel tank. See **Figure 35** to **Figure 37**.
- 7.4.2.2 Remove all traces of dirt, debris and fuel by steam cleaning.
- 7.4.2.3 Drain the tank of all water and ensure that its inside is dry.
- 7.4.2.4 Replace the drain plug.

<i>Sykes Pumps</i>	Ref.No.SY381-4	Issue Status: seventh
OPERATION & MAINTENANCE INSTRUCTIONS	Page 27 of 87	
STANDARD RANGE TRAILER MOUNTED PUMPS	Issued : 9 July	

## 7.5 Vacuum pump drive belt

The vacuum pump pulley arrangement is illustrated below in **Figure 5**.

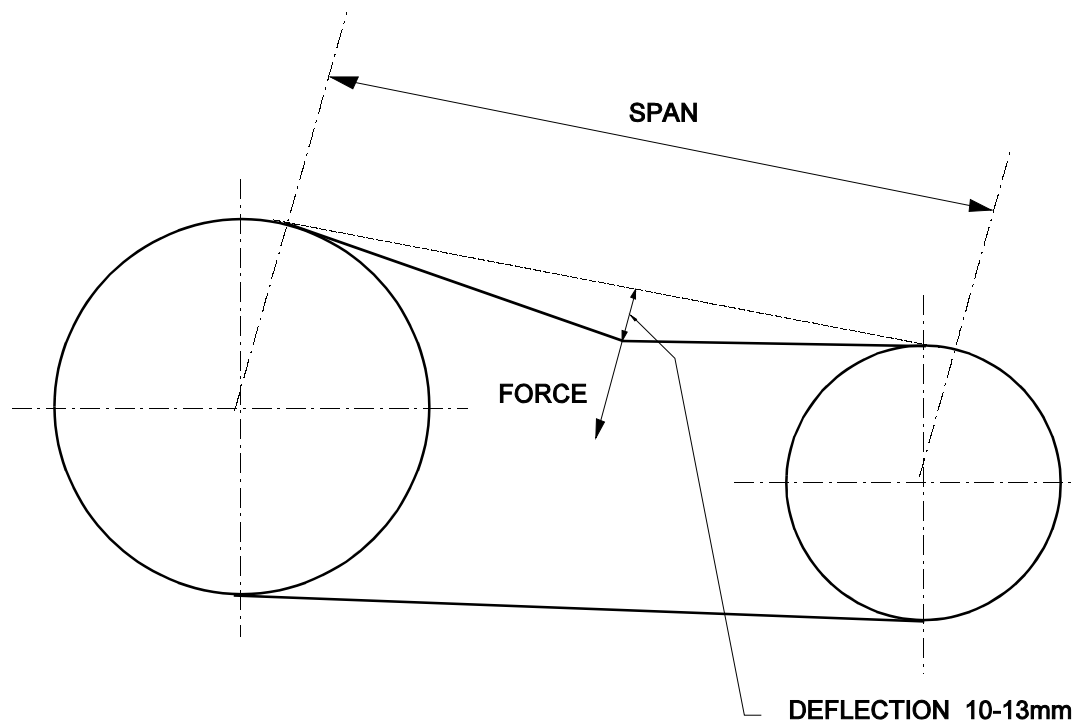

**Figure 5** Vacuum pump pulley arrangement

### 7.5.1 Adjusting belt tension

7.5.1.1 Remove vacuum drive guard.

7.5.1.2 Loosen the vacuum pump mounting holding down nuts.

7.5.1.3 Reposition the vacuum pump to adjust the tension of the belt. (At the correct tension a force of 2.5kg is needed to deflect the belt 10-13mm at the midpoint between the pulleys.)

7.5.1.4 When the vacuum pump is in the correct position, tighten the vacuum pump holding down nuts.

7.5.1.5 Using a straight edge, ensure that the priming pump and main pump pulleys are aligned so that parallel misalignment is less than 5mm per metre between pulley centres, and angular misalignment does not exceed  $\frac{1}{4}^\circ$  (refer to **Figure 6**). Correct the alignment if necessary.

7.5.1.6 Replace the priming pump drive guard.

<i>Sykes Pumps</i>	Ref.No.SY381-4	Issue Status: seventh
OPERATION & MAINTENANCE INSTRUCTIONS	Page 28 of 87	
STANDARD RANGE TRAILER MOUNTED PUMPS	Issued : 9 July	

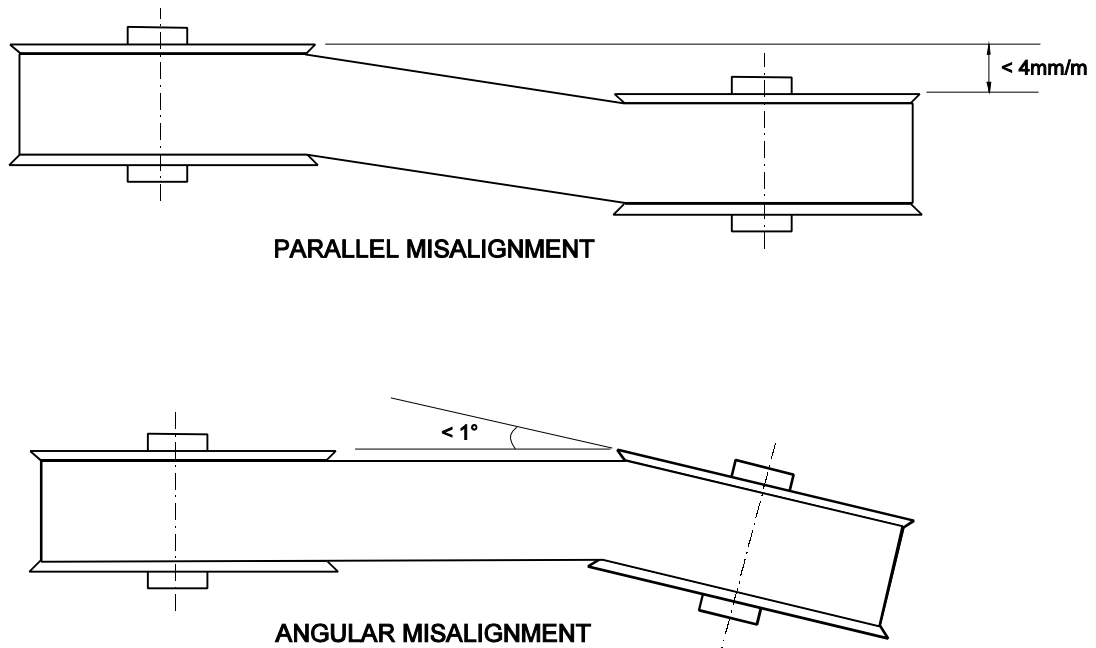

**Figure 6** Belt alignment

## 7.5.2 Renewing the belt

7.5.2.1 Remove vacuum drive guard.

7.5.2.2 Loosen the vacuum pump holding down nuts and slacken the belt.

7.5.2.3 Disassemble the drive coupling (referring to the manufacturer's operation and maintenance instructions for the type of coupling used).

7.5.2.4 Remove the timing belt from its pulleys, fit a new belt and adjust the tension as described in Section 7.5.1 (ensuring correct teeth/pulley seating).

7.5.2.5 Reassemble the drive coupling as per manufacturer's instructions.

7.5.2.6 Replace all guarding.

## 7.6 Coalescer oil feed and filters

### 7.7 Coalescer

Check the coalescer oil level daily. This should be level with the neck of the filler cap. Drain any water present in the coalescer by using the drain cock provided. If excessive water is found or the oil appears dirty, the oil and coalescent filters should be inspected. Clean these filters if they prove to be contaminated.

<i>Sykes Pumps</i>	Ref.No.SY381-4	Issue Status: seventh
OPERATION& MAINTENANCE INSTRUCTIONS	Page 29 of 87	
STANDARD RANGE TRAILER MOUNTED PUMPS	Issued : 9 July	

Other maintenance of the coalescer is limited to regular cleaning of the oil and coalescent filters. The oil filter is located in the oil feed connection to the vacuum priming pump. The coalescent filter is situated underneath the coalescer lid.

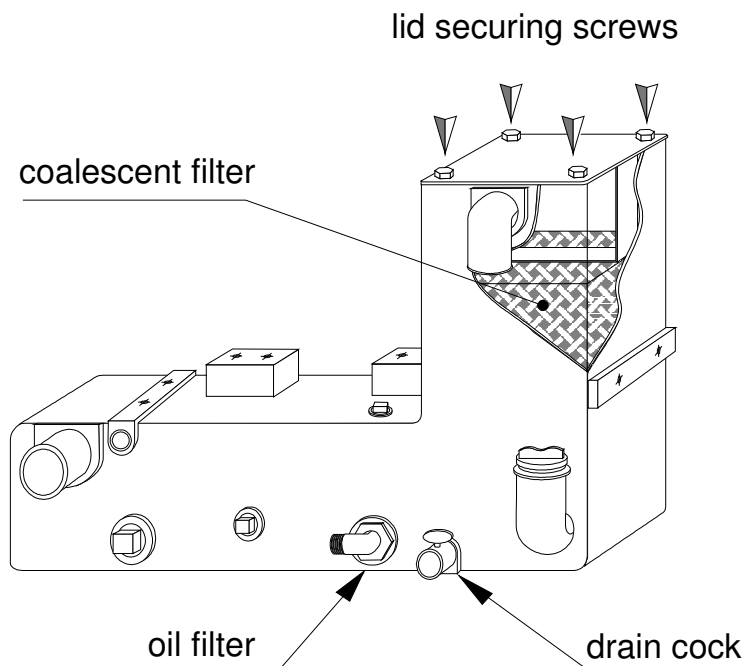
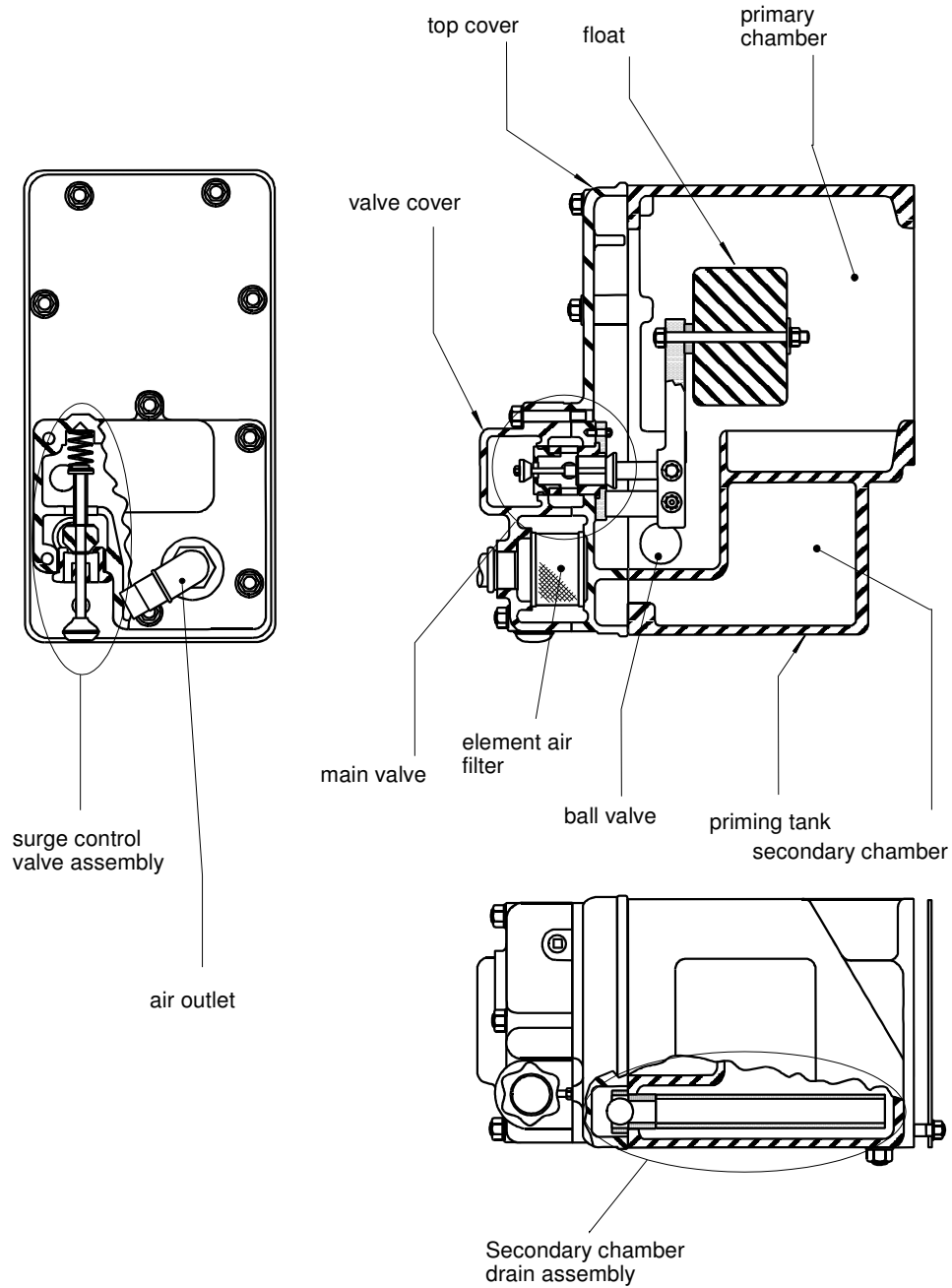

**Figure 7** Coalescer filter removal

- 7.7.0.1 Drain the oil from the coalescer by unscrewing the drain cock.
- 7.7.0.2 Remove the four screws (shown as '➤' in **Figure 7**, page 29).
- 7.7.0.3 Remove the lid and the filter retainer.
- 7.7.0.4 Lift out the coalescent filter.
- 7.7.0.5 Detach the vacuum pump oil feed pipe and unscrew the oil supply connection on the coalescer.
- 7.7.0.6 Remove the oil filter.
- 7.7.0.7 Clean the coalescent and oil filters with a suitable solvent and fully dry both filters.
- 7.7.0.8 Reassembly is a straightforward reversal of disassembly. Cleaning or renewing the coalescer mesh.

<i>Sykes Pumps</i>	Ref.No.SY381-4	Issue Status: seventh
OPERATION & MAINTENANCE INSTRUCTIONS	Page 30 of 87	
STANDARD RANGE TRAILER MOUNTED PUMPS	Issued : 9 July	

## 7.8 Priming tank air filter, surge control valve and air valve



**Figure 8** Vacuum priming tank

<i>Sykes Pumps</i>	Ref.No.SY381-4	Issue Status: seventh
OPERATION& MAINTENANCE INSTRUCTIONS	Page 31 of 87	
STANDARD RANGE TRAILER MOUNTED PUMPS	Issued : 9 July	

**Figure 9** shows the air and surge control valve assemblies , indicating areas that should be checked for wear and damage. To access the valves or for cleaning out, remove the priming tank top complete with valve gear. Renew parts, as necessary and grease valve seats to prevent seizure.

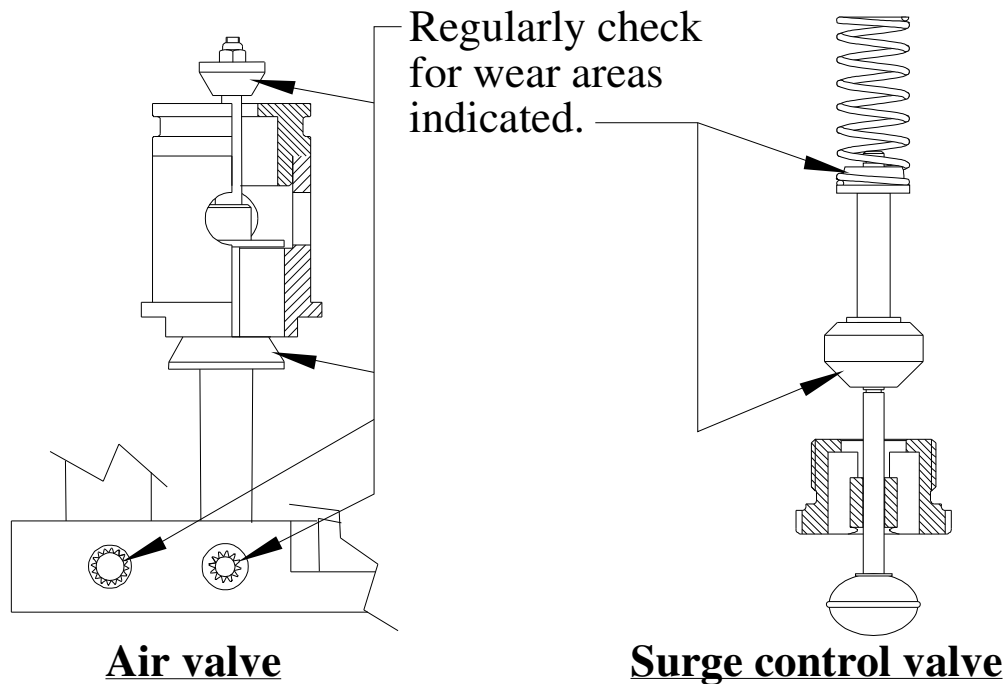

**Figure 9** Priming tank air and surge control valves

## 7.9 Vacuum pump

### 7.9.1 Removing the vacuum pump

See ? on page 65.

#### WARNING

Lifting equipment **IS** required to remove the 60 ft<sup>3</sup>/min vacuum pump, where fitted. Check Technical Specification, section 5.2.

- 7.9.1.1 Remove vacuum drive guard.
- 7.9.1.2 Disconnect hoses from the vacuum pump.
- 7.9.1.3 Using a suitable spanner, disconnect the oil feed pipe at the vacuum pump and withdraw the oil feed pipe.
- 7.9.1.4 Loosen the vacuum pump holding down nuts.
- 7.9.1.5 Remove the timing belt.
- 7.9.1.6 Remove the vacuum pump and pulley.

<i>Sykes Pumps</i>	Ref.No.SY381-4	Issue Status: seventh
OPERATION& MAINTENANCE INSTRUCTIONS	Page 32 of 87	
STANDARD RANGE TRAILER MOUNTED PUMPS	Issued : 9 July	

## 7.9.2 Dismantling the vacuum pump

### CAUTION

Dismantling the pump should be done in clean workshop conditions. Have swabs available to soak up any oil remaining in the pump.

refer to ? and **Figure 30**

7.9.2.1 Remove the priming pump pulley, complete with Taper Lock® bush as follows:

7.9.2.1.1 Slacken, by several turns, all screws in the Taper Lock® bush. Remove one or two, according to the number of jacking holes (shown as '●' in **Figure 10**).

7.9.2.1.2 Oil the thread of each screw, the point of grub screws and under the head of cap screws. Insert the screws into the jacking holes.

7.9.2.1.3 Tighten the screws alternately until the bush is loosened in the hub and the assembly is free on the shaft.

7.9.2.1.4 Withdraw the priming pump pulley, complete with Taper Lock® bush.

7.9.2.2 Remove the dowel and key from the priming pump shaft keyway.

7.9.2.3 Remove the non-drive end cover and withdraw the rotor assembly.

7.9.2.4 Withdraw each blade in turn and examine for damage, tip wear, face wear or distortion (*refer to **Figure 11** and **Table 6** for limits*).

7.9.2.5 Check the bearings for signs of overheating, flaking, undue wear, uneven wear or indentation.

7.9.2.6 Check the oil seals, joints, dowels and 'o'-rings, renew where necessary.

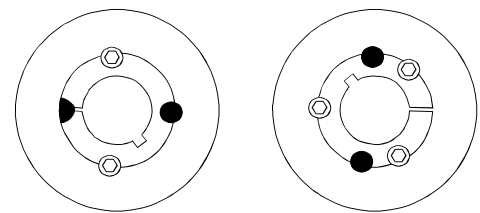

**Figure 10** - Taper Lock® screw positions

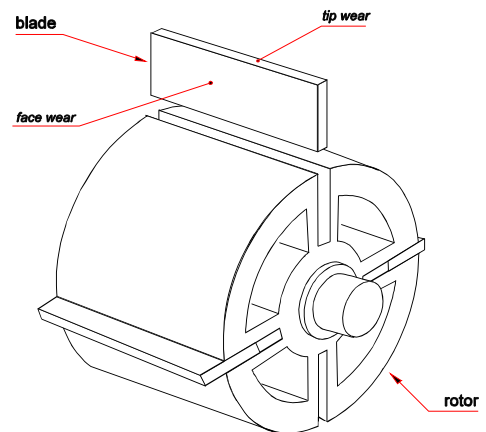

**Figure 11** - vacuum pump rotor



<i>Sykes Pumps</i>	Ref.No.SY381-4	Issue Status: seventh
OPERATION& MAINTENANCE INSTRUCTIONS	Page 33 of 87	
STANDARD RANGE TRAILER MOUNTED PUMPS	Issued : 9 July	

**Table 6** Vacuum pump clearance and dimensions

PARAMETER	25 cfm		60 cfm	
	MAX (mm)	MIN (mm)	MAX (mm)	MIN (mm)
Rotor end clearance	0.180	0.080	0.250	0.100
Blade end clearance	0.173	0.066	0.205	0.075
Top clearance	0.075	0.051	0.102	0.075
Blade length	89.925	89.870	109.925	109.870
Minimum blade width		27.0		48
Maximum difference in blade thickness	0.5		0.5	

### 7.9.3 Reassembling the vacuum pump

Consult **Figure 30**, page 69. All components must be clean and lightly oiled.

- 7.9.3.1 Fit the outer races in both covers. In each case, fit the outer circlip so that the ends straddle the bearing lubrication hole where it enters the bore, so that there is no blockage or restriction on the oil flow. Then press in the outer race to just touch the circlip. Fit the inner circlip.
- 7.9.3.2 Fit the shaft oil seal in the drive end cover. Note that the oil seal must be fitted with the lip facing outwards.
- 7.9.3.3 Fit the O-rings in each cover groove and in both oil feed hole recesses.
- 7.9.3.4 Press the bearing inner races into position on the rotor shaft.
- 7.9.3.5 Fit the drive end cover to the stator, engaging the dowels and tightening the cover screws to a torque of 30 Nm.
- 7.9.3.6 Carefully slide the rotor and bearing into the drive end cover, engaging the bearing squarely and supporting the non-drive end of the rotor level.
- 7.9.3.7 Insert the blades into the rotor slots.
- 7.9.3.8 Fit the non-drive end cover, carefully engaging the bearings and then the dowels. Take care not to damage the oil seal during assembly.
- 7.9.3.9 Tighten the cover screws to 30 Nm. Fit the non-drive end bearing cover plate and joint.
- 7.9.3.10 Inspect the check valve disc, spring and seating for corrosion, damage or excessive wear.
- 7.9.3.11 Check that the assembled unit rotates freely.
- 7.9.3.12 Refit the pulley and the Taper Lock® bush as follows:
  - 7.9.3.12.1 Fit the key and fill the empty holes on the Taper Lock® bush to exclude dirt.
  - 7.9.3.12.2 Where applicable, remove the protective coating from the bore and the outside of the Taper Lock® bush and bore of the pulley.
  - 7.9.3.12.3 Ensure that mating surfaces are completely clean and free from oil and dirt.
  - 7.9.3.12.4 Insert the bush into the pulley, ensuring that the holes are aligned.

<i>Sykes Pumps</i>	Ref.No.SY381-4	Issue Status: seventh
OPERATION& MAINTENANCE INSTRUCTIONS	Page 34 of 87	
STANDARD RANGE TRAILER MOUNTED PUMPS	Issued : 9 July	

- 7.9.3.12.5 Oil the thread and point (grub screws) or thread and under the head (cap-head screws) of each of the removed screws. Insert them loosely into the holes threaded in the hub.
- 7.9.3.12.6 Clean the shaft and fit the pulley and bush to the shaft as one unit. Locate this assembly in position to give correct drive and keyway alignment.

---

 **NOTE:** When tightening the screws, the Taper Lock® bush will nip the shaft and then the pulley will be drawn slightly onto the bush.

---

- 7.9.3.12.7 Tighten all screws gradually and alternately until all are pulled up very tightly.
- 7.9.3.12.8 Hammer against the large end of the bush, using a block or sleeve as a drift to prevent damage. The screws should now turn a little more.
- 7.9.3.12.9 Repeat the above two steps until no further adjustment is achieved.

#### **7.9.4 Refitting vacuum pump**

See ?, page 65.

- 7.9.4.1 Put the vacuum pump in place on the mounting bracket.
- 7.9.4.2 Refit the belt over the vacuum pump pulley (05) and adjust the position of the vacuum pump to gain the correct tension on the belt (see Section 7.5.1).
- 7.9.4.3 Fit and tighten the vacuum pump holding nuts (19).
- 7.9.4.4 Adjust the belt tension and tighten the vacuum pump mounting locking screws as explained in Section 7.5.1, page 27.
- 7.9.4.5 Refit the vacuum and exhaust hoses to the vacuum pump, ensuring each is refitted in the same position from which it was removed. Check that the fittings are tight.
- 7.9.4.6 Check that the oil feed pipe is clean. Refit the pipe and check that the fitting is tight.
- 7.9.4.7 The Taper Lock® bush screws should be checked for tightness after the machine has been run under load for a short time.

<i>Sykes Pumps</i>	Ref.No.SY381-4	Issue Status: seventh
OPERATION& MAINTENANCE INSTRUCTIONS	Page 35 of 87	
STANDARD RANGE TRAILER MOUNTED PUMPS	Issued : 9 July	

## 7.10 Non-return valve

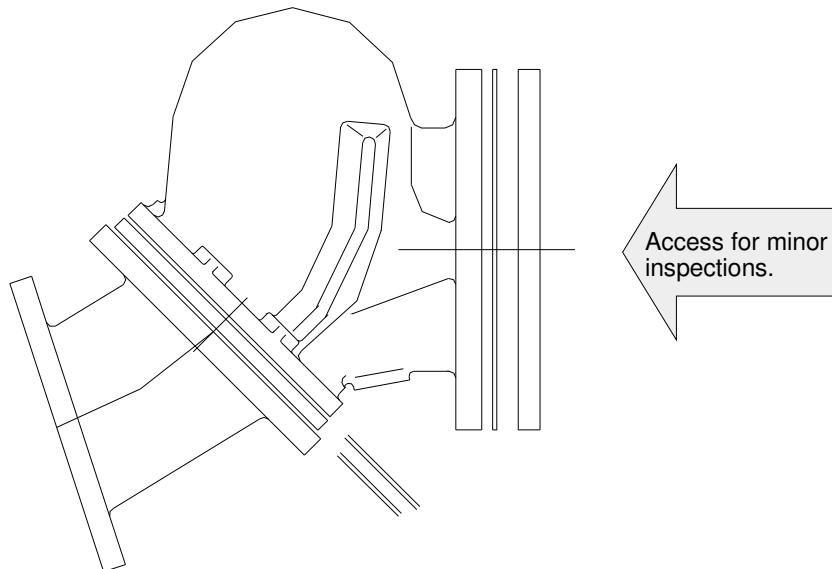

**Figure 12** Non-return valve

7.10.0.1 Regularly check the non-return valve, **Figure 12**, for blockage and wear.

7.10.0.2 For a thorough inspection;

- 7.10.0.2.0.1 disconnect the non-return valve from the adaptor bend and remove it;
- 7.10.0.2.0.2 detach the valve seat, remove the ball and inspect both for wear and damage;
- 7.10.0.2.0.3 re-fit or renew as appropriate.

## 7.11 Greasing the main pump bearings

Grease the main pump bearings through the two nipples, shown in **Figure 21** and **Figure 22** on pages 53 and 55, with five shots of the recommended grease (See **Table 1**, page 11).

## 7.12 Main pump impeller and wear plates

To check the condition of the impeller and wear plates without removing the main pump:

- 7.12.0.1 Drain the volute.
- 7.12.0.2 Disconnect the intake hose and fittings.
- 7.12.0.3 Disconnect the volute from the priming tank.
- 7.12.0.4 Consult **Figure 24** and **Figure 25** on pages 59 and 61. Remove the priming tank and front cover and front wear plate sump tee assembly by removing peripheral nuts in volute housing (suction side). The front wear plate can be separated from the front cover by removing the three nuts located towards its own centre.

<i>Sykes Pumps</i>	Ref.No.SY381-4	Issue Status: seventh
OPERATION& MAINTENANCE INSTRUCTIONS	Page 36 of 87	
STANDARD RANGE TRAILER MOUNTED PUMPS	Issued : 9 July	

## WARNING

Lifting gear may be required to remove the priming tank.

- 7.12.0.5 Remove the impeller assembly by unscrewing in an anti-clockwise direction, looking at the impeller end.
- 7.12.0.6 Extract the back wear plate by removing the nuts on the back cover plate and withdrawing the wear plate through the front of the volute.
- 7.12.0.7 Extract the packing holder through the front of the volute. If the packing needs renewing, follow the instructions in Section 7.13.2, page 37.
- 7.12.0.8 Check the packing holder for wear and renew the rubber O-ring, if necessary.
- 7.12.0.9 Check the wear plates and the impeller for wear and renew, if necessary.
- 7.12.0.10 If necessary, renew the wear ring and sleeve fitted to the hub of the impeller. Ensure that the ring is fitted squarely and securely to avoid damaging the pump pressure seal.
- 7.12.0.11 Refit the impeller and set the front and back clearances using shims as explained in Section 7.15.4, page 41.

## 7.13 Main pump pressure seal

The main pump pressure seal is shown in **Figure 23** on page 57.

Renewal of the pump pressure seal packing can be undertaken during regular inspection of the impeller and wear plates as explained in Section 7.12, page 35. If the pump pressure seal needs to be inspected at other times it can be removed and refitted through the back of the volute as explained in Section 7.13.1, below.

### 7.13.1 Removing and refitting pump pressure seal

- 7.13.1.1 Release the set screws holding the pump pressure seal assembly to the back plate assembly and slide along the pump shaft. This will automatically withdraw the packing holder.
- 7.13.1.2 Replace the packing as described in Section 7.13.2 below.
- 7.13.1.3 Slide the packing holder back up to sleeve face and refit the seal assembly. Tighten evenly.

### 7.13.2 Renewing the pump pressure seal packing

- 7.13.2.1 Cut a 270mm length of 1/2" square packing material.
- 7.13.2.2 Place the packing in the holder, butting the two ends first and then pressing the rest of the packing into the holder. The total length of packing is greater than the circumference of the holder and must be forced into place. The packing will protrude slightly from the face of the holder on completion.

<i>Sykes Pumps</i>	Ref.No.SY381-4	Issue Status: seventh
OPERATION& MAINTENANCE INSTRUCTIONS	Page 37 of 87	
STANDARD RANGE TRAILER MOUNTED PUMPS	Issued : 9 July	

## 7.14 Dismantling the drive

### 7.14.1 Tyre coupling

7.14.1.1 Thoroughly clean all components, paying particular attention to the removal of the protective coating in flange bores and on bushes.

7.14.1.2 Fit flanges to the shafts after placing the external clamp rings on the shafts (where Taper Lock ® flanges are used, follow relevant instructions provided). Locate flanges so that dimension 'M' is obtained (See **Figure 13**). In case of clamps with internal clamping rings, fit the clamping rings next, but engage only two or three pitches of the screw thread at this stage.

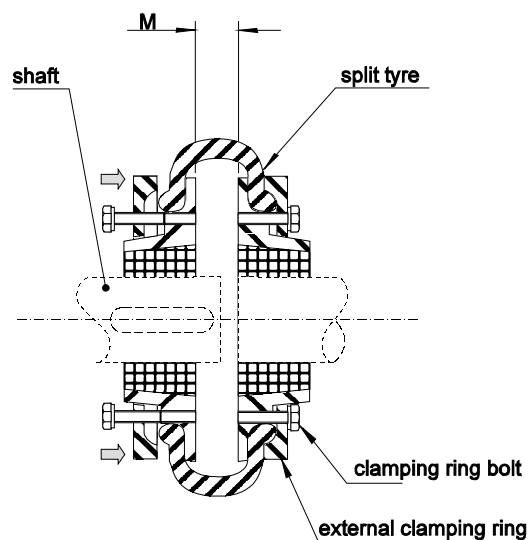

**Figure 13** Tyre coupling assembly

**Table 7** Clamping Screw Coupling Torque and Flange Spacing 'M'

Coupling size	F40	F50	F60	F70	F80	F90	F100	F110	F120	F140	F160	F180	F200	F220	F250
M (mm)	22	25	33	23	25	27	27	25	29	32	30	46	48	55	59
Screw size	M6	M6	M6	M8	M8	M10	M10	M10	M12	M12	M16	M16	M16	M20	M20
Screw torque (Nm)	15	15	15	24	24	40	40	40	50	55	80	105	120	165	165

7.14.1.3 Bring shafts into line until dimension 'M' is obtained (See **Figure 13**). If shaft end float is to occur, locate the shafts at mid-position of end float when checking dimension 'M'.

**NOTE:** Shaft ends may project beyond the faces of the flanges, if required. In this event, allow sufficient space between shaft ends for end float and mid-alignment.

Check parallel alignment by laying a straight edge across the flanges at several positions around the

**Table 8** Coupling gap setting

Coupling size	F40 to F60	F70 to F120	F140 to F160	F180 to F250
Tyre Gap (mm)	2	3	5	6

circumference. Check angular alignment by measuring the gap between flanges at several positions around the circumference. Attempt to align the coupling as accurately as possible, particularly on high speed applications.

<b>Sykes Pumps</b>	Ref.No.SY381-4	Issue Status: seventh
OPERATION& MAINTENANCE INSTRUCTIONS	Page 38 of 87	
STANDARD RANGE TRAILER MOUNTED PUMPS	Issued : 9 July	

7.14.1.4 Open out tyre and fit over coupling flanges ensuring that the tyre beads seat properly on the flanges. To ensure proper seating, strike the outside diameter of the tyre with a small mallet . When seated, **Table 7** specifies the gap between the ends of the tyre.

7.14.1.5 Tighten the clamping ring screws alternately and evenly (half a turn at a time), working round each flange until the required screw torque (indicated in **Figure 13**) is achieved.

### 7.14.2 Flywheel coupling installation

7.14.2.1 Thoroughly clean all components, paying particular attention to the removal of the protective coating in the bore of the driven flange.

7.14.2.2 Slip bolt ring, clamping ring, and then element (with large diameter facing flywheel) onto driven shaft. Fit flange to shaft. ( Where Taper Lock® flange is used, see separate fitting instructions supplied with the Taper Lock ® bush.). Locate flange on shaft so that dimension M will be achieved on assembly (See next paragraph).

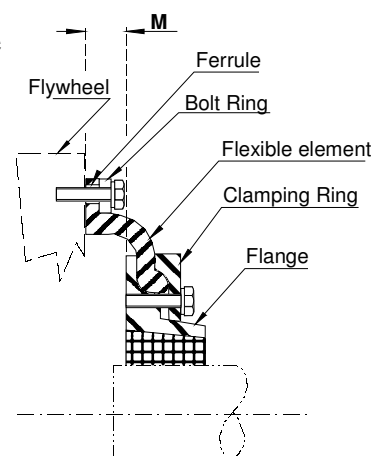

7.14.2.3 Bring driven shaft into line with flywheel until dimension M is correct (See **Figure 14**). If shaft and end float is to occur, locate driven shaft at mid position of end float when checking dimension M . Note that driven shaft may project beyond the face of the flange, if required. In this event, allow sufficient space between shaft end and flywheel for end float and misalignment.

**Figure 14** Flywheel coupling

7.14.2.4 Accurately align driven shaft with flywheel. Check both parallel and angular alignment by mounting a dial indicator near the outside diameter of the flange (See **Figure 14**, **Figure 16** and **Figure 15**.) and rotating the flywheel through 360°. Indicator readings for both parallel and angular alignment should not exceed the values given in **Figure 14** . Then bolt driven machine in place.

<b>Sykes Pumps</b>	Ref.No.SY381-4	Issue Status: seventh
OPERATION& MAINTENANCE INSTRUCTIONS	Page 39 of 87	
STANDARD RANGE TRAILER MOUNTED PUMPS	Issued : 9 July	

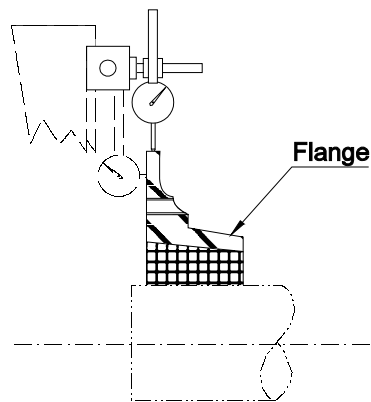

**Figure 16** Shaft alignment

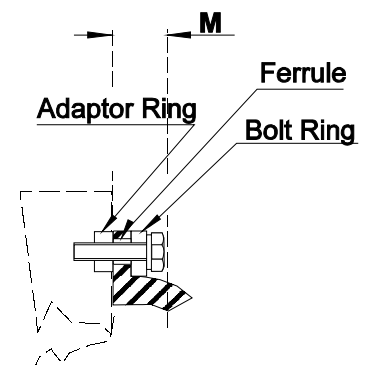

**Figure 15** 213W (element size) only

**Table 9** - Flywheel settings

Element size		87	96	112	116	131	135	172	192	213	252
<b>M</b>	mm	35	40	41	41	55	57	68	76	86§	132
Lr	mm	—	—	—	—	93	95	111	123	156	200
Max. indicator reading	mm	.51	.63	.76	.76	.89	.89	1.14	1.27	1.40	1.52
Flange size		F70	F80	F100	F100	F110	F110	F140	F160	F180	F220
Torque *	Bolt ring	Nm	24	32	32	32	32	35	35	54	75
	Clamping ring	Nm	24	24	40	40	40	40	55	80	105

**Note:** It may be necessary to back off the shaft to allow room to remove and replace the flexible element.

\*\* The recommended clamping ring screw torques do not give metal to metal contact between clamping ring and flange.

§ For 213W Flywheel coupling M=104 mm when adaptor ring fitted. See .

7.14.2.5 Place flexible element and bolt ring <sup>1</sup> in position, fit screws finger tight. Place clamping ring I position and fit screws finger tight.

7.14.2.6 Working alternately and evenly round each flange, tighten each screw (approx. ½ turn) until the required screw torques are achieved.

## 7.15 Main pump shaft and bearings

Checking and renewing the bearings of the main pump must be done in clean and dust-free conditions.

7.15.0.1 Remove the drive coupling, as described in Section 7.14.

7.15.0.2 Remove vacuum pump drive-belt (See sub-section 7.9).

7.15.0.3 Disconnect the bearing housing bracket from the coalescer by removal of fixings 12 & 14 as shown on **Figure 21** and **Figure 22**.

7.15.0.4 Remove the volute fixing positions, which are shown in **Figure 35**, **Figure 36** and **Figure 37** starting on page 77.

7.15.0.5 The pump-end can, now, be removed using suitable lifting equipment -remove sump-Tee first, if required.

<i>Sykes Pumps</i>	Ref.No.SY381-4	Issue Status: seventh
OPERATION& MAINTENANCE INSTRUCTIONS	Page 40 of 87	
STANDARD RANGE TRAILER MOUNTED PUMPS	Issued : 9 July	

Test the pump before its return to service. See Section 6.7, page 21.

### 7.15.1 Dismantling the shaft and bearings

- 7.15.1.1 Remove the priming equipment as described in Section 7.12.
- 7.15.1.2 Refer to **Figure 21** and **Figure 22**. Disconnect the bearing frame from the volute.
- 7.15.1.3 Remove the liquid thrower and the pump end grease retainer.
- 7.15.1.4 Remove the end caps from both the drive and pump ends of the shaft.
- 7.15.1.5 The shaft can now be removed complete with the back-to-back drive-end bearings (angular contact ball bearings) and the inner race of the pump-end bearing (roller bearing).
- 7.15.1.6 To remove the drive-end bearings, remove the tab from the lock nut , loosen the lock nut, and remove the tab washer and drive end grease retainer.

### 7.15.2 Renewing/re-fitting the bearings

#### CAUTION

To avoid damage to bearings, **DO NOT** heat the bearings to temperatures above 120°C.

On size 213W only, place bolt ring adaptor between flexible element and flywheel. Line up unthreaded holes in adaptor with threaded holes in flywheel and fix 6 long screws into these holes. Fix the 6 short screws in the other holes.

- 7.15.2.1 Remove the pump-end roller bearing from its packaging and degrease.
- 7.15.2.2 Press the outer race into the pump end of the bearing frame.
- 7.15.2.3 Fit the pump-end bearing end-cap and secure it with screws.
- 7.15.2.4 Place the shaft in a vice. Heat the inner race of the pump end bearing to 110°C on a bearing heater.
- 7.15.2.5 Fit the heated bearing race onto the pump end of the shaft and knock home to shoulder.
- 7.15.2.6 Remove the drive-end angular contact ball races from their packaging and degrease.
- 7.15.2.7 Heat and fit the bearings onto the drive end of the shaft, knocking home to the shoulder as before. The bearings are fitted back-to-back as shown in **Figure 21** and **Figure 22**.
- 7.15.2.8 Insert the shaft into position in the bearing housing through the drive-end.
- 7.15.2.9 Fit the grease retainer and secure it with its grub screw.
- 7.15.2.10 Fit the drive end grease retainer, tab washer and lock nut. Tighten the lock nut until the tab aligns and bend the tab into locating slot.
- 7.15.2.11 Fit the drive-end end cap, using a grease and oil resistant sealant on the mating faces. Tighten the set screws to a suitable torque for M10 x GR8.8.
- 7.15.2.12 Fit the liquid thrower on the pump end of the shaft.
- 7.15.2.13 Grease all bearings, using the recommended grease or its equivalent. See **Table 1**, page 11.

### 7.15.3 Fitting the bearing frame

- 7.15.3.1 Before fitting the bearing frame to the volute check that;



<i>Sykes Pumps</i>	Ref.No.SY381-4	Issue Status: seventh
OPERATION& MAINTENANCE INSTRUCTIONS	Page 41 of 87	
STANDARD RANGE TRAILER MOUNTED PUMPS	Issued : 9 July	

- 7.15.3.1.1 the pressure seal is fitted with new packing and fitted on the shaft;
- 7.15.3.1.2 all studs are securely in place on the volute;
- 7.15.3.1.3 the gasket is in place and undamaged (Renew if necessary);

**Table 10** Impeller clearances

PARAMETER	MAX.	MIN.
Back plate clearance	1.1mm	0.1mm
Front plate clearance	0.60mm	0.40mm

- 7.15.3.1.4 the back cover plate is in position.
- 7.15.3.2 Fit the assembled bearing frame onto the volute assembly and secure with nuts and spring washers.

#### 7.15.4 Fitting the impeller and setting wear plate clearances

- 7.15.4.1 Clean the threaded portion of the shaft and impeller using solvent. Grease threads. Fit 5 of the 1mm impeller shims and screw the impeller into place.
- 7.15.4.2 Set the back clearance. Measure the back clearance between the impeller and the back wear plate. If the clearance is more than the maximum then remove one or more shims to correct. (See **Table 9**) Screw the impeller back into place and make sure it is fully locked up on the shaft.
- 7.15.4.3 Ensure that the machined inner and outer faces of the volute are thoroughly cleaned. Attach the priming tank to the volute, omitting at this stage all the shims. Tighten the securing screws and nuts lightly and evenly until the impeller is locked.
- 7.15.4.4 Measure the gap between the front wear plate and the volute. Note this dimension 'Y' and select shims to equal  $Y + 0.5 \text{ mm}$  ( $Y+0.020$ ").
- 7.15.4.5 Prior to final assembly, coat the outer edges of the wear plate heavily with water pump grease to facilitate removal at a later date.
- 7.15.4.6 Fit the shims between the front cover and the volute.
- 7.15.4.7 Secure the front cover assembly to the volute. Check that the shaft turns freely.

The main pump assembly can now be reinstalled on the chassis (if it was removed) and the hoses and priming tank put back in place.

<i>Sykes Pumps</i>	Ref.No.SY381-4	Issue Status: seventh
OPERATION& MAINTENANCE INSTRUCTIONS	Page 42 of 87	
STANDARD RANGE TRAILER MOUNTED PUMPS	Issued : 9 July	

## 8 SPARE PARTS

---

### 8.1 Introduction

If you require spare parts for your Andrews Sykes pump please contact your local Andrew Sykes depot, telephone (freefone) 0800-211-611.

#### CAUTION

The use of any spares other than those supplied by Andrews Sykes Hire Limited for the machine in question may cause **DAMAGE** to the machine and may **INVALIDATE** any EC Declaration given in respect of the equipment.

### 8.2 Ordering Spares

When ordering spare parts, please provide the following details:

Please provide the following information:

- (1) Machine model and chassis type
- (2) Model-Serial number of the machine
- (3) Part number
- (4) Description of part
- (5) Quantity required

See *Product identification*, page 16 for details of model naming and serial numbers.

<i>Sykes Pumps</i>	Ref.No.SY381-4	Issue Status: seventh
OPERATION& MAINTENANCE INSTRUCTIONS	Page 43 of 87	
STANDARD RANGE TRAILER MOUNTED PUMPS	Issued : 9 July	

<b>2 Wheel Site Trailer - General Arrangement</b>				
<b>Ref</b>	<b>Description</b>	<b>WP150/60</b>	<b>GP150M/60</b>	<b>GP150M/25</b>
1	Lister Engine	SY7801006-1	SY7841002-1	SY7841002-1
2	Stub Shaft	SY3804133	SY3804133	SY3804133
3	Bolt	SY9509552	SY9509552	SY9509552
4	Spring Washer	SY9509808	SY9509808	SY9509808
5	Engine Exhaust Spacer	SY3804372	SY3804372	SY3804372
6	Manifold Gasket	SY9519547	SY9519547	SY9519547
7	Flat Washer	SY9509680	SY9509680	SY9509680
8	Bolt	SY9519549	SY9519549	SY9519549
9	Vac Pump Drive Guard	SY3834214	SY3834214	SY3834214
10	Drive Guard Adaptor Plates	SY9519550	--	--
11	Flat Washer	SY9509678	--	--
12	Spring Washer	SY9509806	--	--
13	Set Screw	SY9519095	--	--
14	Flat Washer	SY9509676	SY9509676	SY9509676
15	Spring Washer	SY9509805	SY9509805	SY9509805
16	Set Screw	SY9519075	SY9519075	SY9519075
17	Coupling Flange, Engine	SY9059038	SY9059624	SY9059624
18	Coupling Flange, Pump	SY9059624	SY9059038	SY9059038
19	Coupling Tyre	SY9059027	SY9059027	SY9059027
20	Taper Lock Bush, Engine	SY9059153	SY3872011	SY3872011
21	Taper Lock Bush, Pump	SY9519551	SY9059184	SY9059184
22	Lifter Bracket	SY3804302-1	SY3804302-1	SY3804302-1
23	Bolt	SY9509605	SY9509605	SY9509605
24	Flat Washer	SY9509684	SY9509684	SY9509684
25	Spring Washer	SY9509812	SY9509812	SY9509812
26	Nut	SY9509657	SY9509657	SY9509657
27	Bolt Tubes	SY3564353	SY3564353	SY3564353
28	Packer Sykes Trailers	SY9519552	SY9519553	SY9519553
29	Set Screw	SY9519554	SY9519554	SY9519554
30	Vac Drive Assembly	See ?		
31	Timing Belt	SY3834181	SY3834181	SY3824029
32	Priming Tank Assembly	See <b>Figure 33</b>		
33	Sump/Tee Assembly	See <b>Figure 40</b>		
34	Non-Return Valve Assembly	See <b>Figure 26</b>		
35	Impeller/Wear Plate	See <b>Figure 24</b>	See <b>Figure 25</b>	

<b>Sykes Pumps</b>	Ref.No.SY381-4	Issue Status: seventh
OPERATION& MAINTENANCE INSTRUCTIONS	Page 44 of 87	
STANDARD RANGE TRAILER MOUNTED PUMPS	Issued : 9 July	

<b>2 Wheel Site Trailer - General Arrangement</b>		<b>Cont'd</b>		
<b>Ref</b>	<b>Description</b>	<b>WP150/60</b>	<b>GP150M/60</b>	<b>GP150M/25</b>
36	Pressure Seal Assembly	See <b>Figure 23</b>		
37	Bearing/Volute Assembly	See <b>Figure 21</b>	See <b>Figure 22</b>	
38	Coalescer Assembly	See <b>Figure 34</b>		
39	Site Trailer Assembly	See <b>Figure 35</b>		
40	M.S. Keybar	SY3874036	--	--
41	Clamp	SY3804409	--	--
42	Adaptor	--	SY9519575	SY9519575
43	Bush	--	SY9519576	SY9519576
44	Battery	SY7004394	SY7004394	SY7004394
45	Terminal -Ve	SY3864068	SY3864068	SY3864068
46		SY3864069	SY3864069	SY3864069
47	Lug Ring 6mm	SY3864066	SY3864066	SY3864066
48	Lug Ring 10mm	SY3864067	SY3864067	SY3864067
49	Cable	SY3864065	SY3864065	SY3864065
50	Cable	SY3872001	SY3872001	SY3872001
51	Screw Soc Csk	SY9519555	SY9519555	SY9519555
52	Washer Sq Flat	SY9519556	SY9519556	SY9519556

<i>Sykes Pumps</i>	Ref.No.SY381-4	Issue Status: seventh
OPERATION& MAINTENANCE INSTRUCTIONS	Page 45 of 87	
STANDARD RANGE TRAILER MOUNTED PUMPS	Issued : 9 July	

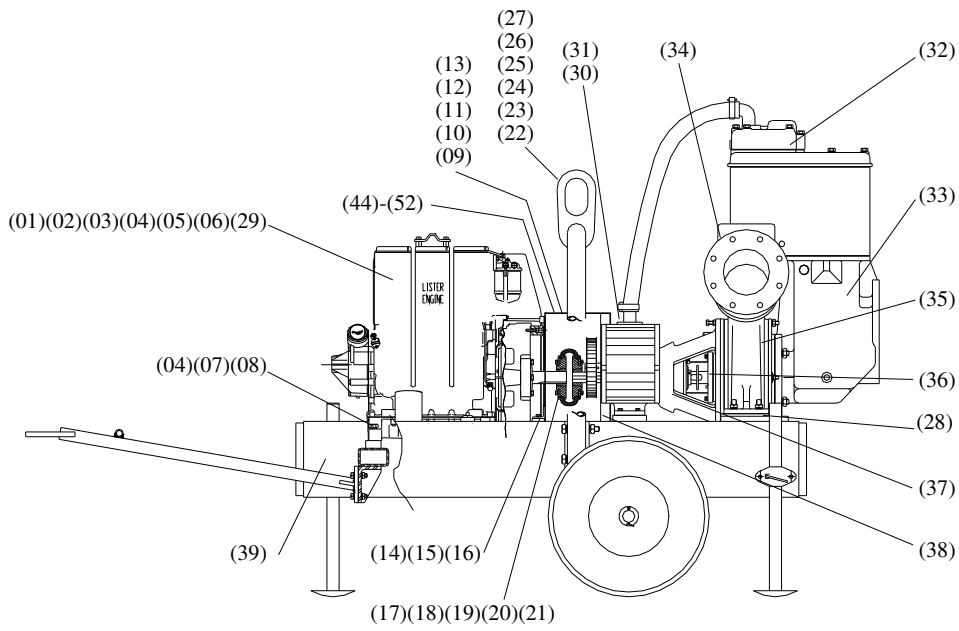

**Figure 17** G.A. of two wheel site trailer

<b>Sykes Pumps</b>	Ref.No.SY381-4	Issue Status: seventh
OPERATION& MAINTENANCE INSTRUCTIONS	Page 46 of 87	
STANDARD RANGE TRAILER MOUNTED PUMPS	Issued : 9 July	

<b>4 Wheel Site Trailer General Arrangement</b>							
Ref	Description	GP100M/25	WP150/60	GP150M/60	GP200/60	GP150M/25	GP200/25
1	Vacuum Drive	SY3834214	SY3834214	SY3834214	SY3475011	SY3834214	SY3475011
2	Shroud Plate	SY9519550	SY9519550	--	SY9519586	--	SY9519586
3		--	--	--		--	
4	Shroud Plate	SY3475013	--	--	--	SY3475013	SY3475014
5	Screw M8	SY9519095	SY9519095	--	SY9519095	SY9519095	SY9519095
6	Washer Flat	SY9509678	SY9509678	--	SY9509678	SY9509678	SY9509678
7	Washer Spring	SY9509806	SY9509806	--	SY9509806	SY9509806	SY9509806
8	Screw M6	SY9519075	SY9519075	SY9519075	SY9519075	SY9519075	SY9519075
9	Washer Flat	SY9509676	SY9509676	SY9509676	SY9509676	SY9509676	SY9509676
10	Washer Spring	SY9019374	SY9019374	SY9019374	SY9019374	SY9019374	SY9019374
11	Nut M6	--	--	--	SY9509651	--	SY9509651
12	Screw Unc	--	--	--	SY3475015	--	SY3475015
13	Washer Flat	--	--	--	SY9509679	--	SY9509679
14	Timing Belt	SY3824029	SY3834196	SY3834196	SY3834185	SY3824029	SY3824029
15	Battery	SY7004394	SY7004394	SY7004394	SY7004497	SY7004394	SY7004497
16	Terminal -Ve	SY3864068	SY3864068	SY3864068	SY3864068	SY3864068	SY3864068
17	Terminal +Ve	SY3864069	SY3864069	SY3864069	SY3864069	SY3864069	SY3864069
18	Lug Ring 6mm	SY3864066	SY3864066	SY3864066	--	SY3864066	--
19	Lug Ring 10mm	SY3864067	SY3864067	SY3864067	SY3864067	SY3864067	SY3864067
20	Battery Box	--	--	--	SY3744257	--	SY3744257
21	Screw Soc Csk	SY9519555	SY9519555	SY9519555	SY9519555	SY9519555	SY9519555
22	Washer Sq Flat	SY9519556	SY9519556	SY9519556	--	SY9519556	--
23	Lifter	SY3804301	SY3804301	SY3804301	SY3804302	SY3804301	SY3804302
24	Bolt Tube	SY3564353	SY3564353	SY3564353	SY3564353	SY3564353	SY3564353
25	Bolt M20	SY9509605	SY9509605	SY9509605	SY9509605	SY9509605	SY9509605
26	Nut M20	SY9509657	SY9509657	SY9509657	SY9509657	SY9509657	SY9509657
27	Washer Spring M20	SY9509812	SY9509812	SY9509812	SY9509812	SY9509812	SY9509812
28	Washer Flat M20	SY9509684	SY9509684	SY9509684	SY9509684	SY9509684	SY9509684
29	Cable	SY3864065	SY3864065	SY3864065	SY9519558	SY3864065	SY9519558
30	Cable	SY3872001	SY3872001	SY3872001	SY9519558	SY3872001	SY9519558
31	Stub Shaft	SY3804133	SY3804133	SY3804133	SY3844104	SY3804133	SY3844104
32	Washer Spring	SY9509806	SY9509806	SY9509806	SY9509806	SY9509806	SY9509806
33	Screw M8	SY9519096	SY9519096	SY9519096	SY9519096	SY9519096	SY9519096
34	Drive Flange Cpl'g	SY9059038	SY9059038	SY9059624	SY9059627	SY9059624	SY9059627
35	Drive T-Lock Bush	SY9519551	SY9519551	SY3872011	SY9059199	SY3872011	SY9059199
36	Driven Flange Cpl'g	SY9059624	SY9059624	SY9059038	SY9059626	SY9059038	SY9059626

<b>Sykes Pumps</b>	Ref.No.SY381-4	Issue Status: seventh
OPERATION& MAINTENANCE INSTRUCTIONS	Page 47 of 87	
STANDARD RANGE TRAILER MOUNTED PUMPS	Issued : 9 July	

<b>4 Wheel Site Trailer General Arrangement</b>				<b>Cont'd</b>			
Ref	Description	GP100M/2 5	WP150/60	GP150M/60	GP200/60	GP150M/25	GP200/25
37	Driven T-Lock Bush	SY905915	SY9059153	SY9059184	SY9059199	SY9059153	SY9059341
38	Coupling Tyre	SY9059027	SY9059027	SY9059027	SY9059029	SY9059027	SY9059029
39	Engine Shaft Key	SY3874036	SY3874036	SY3874036	SY3834103	SY3874036	SY3834103
40	Stub Shaft Bolts	SY9509552	SY9509552	SY9509552	SY9509542	SY9509552	SY9509542
41	Washer Spring	SY9509808	SY9509808	SY9509808	SY9519562	SY9509808	SY9519562
42	Engine	SY7841003-	SY7801009-1	SY7841004-1	SY7841080	SY7841004-1	SY7841080
43	Screw	SY9519549	SY9519549	SY9519549	SY9519563	SY9519549	SY9519563
44	Washer Flat	SY9509680	SY9509680	SY9509680	SY9509682	SY9509680	SY9509682
45	Washer Spring	SY9509808	SY9509808	SY9509808	SY9509810	SY9509808	SY9509810
46	Gasket Manifold	SY9519547	SY9519547	SY9519547	--	SY9519547	--
47	Spacer Eng Exhaust	SY3804372	SY3804372	SY3804372	--	SY3804372	--
48	Packer	SY9519552	SY9519552	SY9519553	SY9519553	SY9519553	SY9519553
49							
50							
51							
52							
53							
55		--	--	--			
56		--	--	--		--	
57	Coalescer	See Figure 34					
58	Non Return Valve	See Figure 26					
59	Priming Tank	See Figure 34	See Figure 35				
63	Pressure Seal	See Figure 23					
64	Impeller/Wear Plate	See Figure 24		See Figure 25			
65	Vac Pump Drive	See Figure 29					
66	Chassis Assembly	See Figure 36					
67	Clamp H/D	SY3804409	SY3804409	SY3804409	SY3804409	SY3804409	SY3804409
68	Radiator Guard	--	--	--	SY3844105	--	SY3844105
69	Bolt M16	--	--	--	SY9519570	--	SY9519570
70	Washer M16	--	--	--	SY9509682	--	SY9509682
71	Washer Spring M16	--	--	--	SY9509810	--	SY9509810

<i>Sykes Pumps</i>	Ref.No.SY381-4	Issue Status: seventh
OPERATION& MAINTENANCE INSTRUCTIONS	Page 48 of 87	
STANDARD RANGE TRAILER MOUNTED PUMPS	Issued : 9 July	

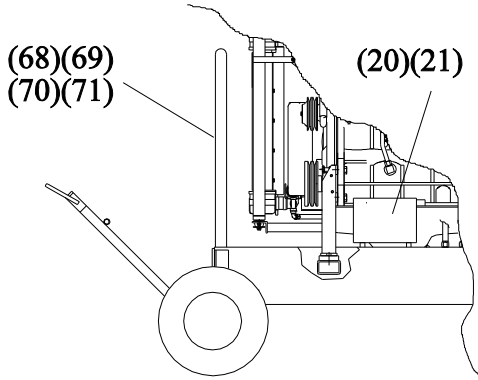

**Figure 19 GP200 Only**

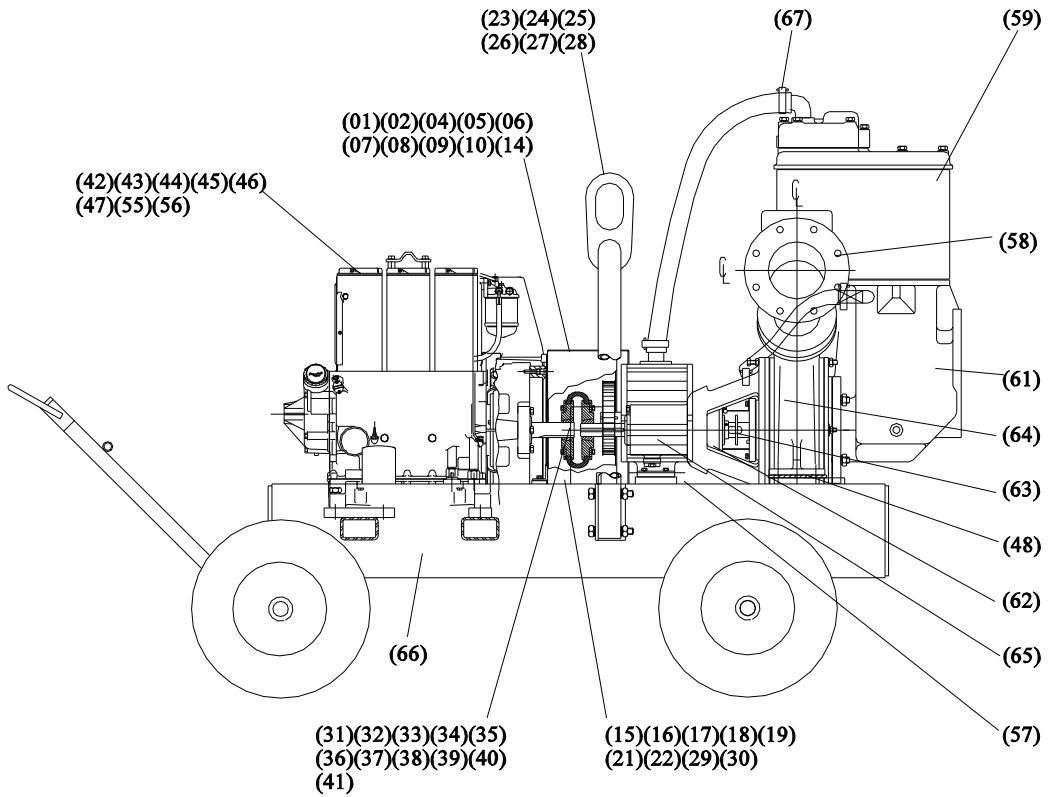

**Figure 18 G.A. of 4-Wheel Site Trailer**



<b>Sykes Pumps</b>	Ref.No.SY381-4	Issue Status: seventh
OPERATION& MAINTENANCE INSTRUCTIONS	Page 49 of 87	
STANDARD RANGE TRAILER MOUNTED PUMPS	Issued : 9 July	

<b>2 Wheel High Speed Trailer General Arrangement</b>				
<b>Item</b>	<b>Description</b>	<b>GP150M/25</b>	<b>GP150M/60</b>	<b>GP100M/25</b>
1	Lister Engine	SY7841004-1	SY7841004-1	SY7841004-1
2	Stub Shaft	SY3804133	SY3804133	SY3804133
3	Bolt	SY9509552	SY9509552	SY9509552
4	Set Screw	SY9519563	SY9519563	SY9519563
5	Flat Washer	SY9509680	SY9509680	SY9509680
6	Spring Washer	SY9509808	SY9509808	SY9509808
7	Engine Exhaust Spacer	SY3804372	SY3804372	SY3804372
8	Manifold Gasket	SY9519547	SY9519547	SY9519547
9	Coupling Flange	SY9059038	SY9059038	SY9059624
10	Coupling Flange	SY9059624	SY9059624	SY9059624
11	Tyre Fenaflex	SY9059027	SY9059027	SY9059027
12	Taper Lock Bush	SY3872011	SY3872011	SY9519551
13	Taper Lock Bush	SY9059184	SY9059184	SY9059153
14	Vacuum Pump Drive Guard	SY3834214	SY3834214	SY3834214
15	Guard Shroud Plates	SY3475013	--	SY3475013
16	Set Screw	SY9519095	--	SY9519095
17	Flat Washer	SY9509678	--	SY9509678
18	Spring Washer	SY9509806	SY9509806	SY9509806
19	Set Screw	SY9519075	SY9519075	SY9519075
20	Flat Washer	SY9019353	SY9019353	SY9019353
21	Spring Washer	SY9509805	SY9509805	SY9509805
22	Lifter Bracket	SY3804302-1	SY3804302-1	SY3804302-1
23	Bolt	SY9509605	SY9509605	SY9509605
24	Nut	SY9509657	SY9509657	SY9509657
25	Flat Washer	SY9509684	SY9509684	SY9509684
26	Spring Washer	SY9509812	SY9509812	SY9509812
27	Bolt Tubes	SY3564353	SY3564353	SY3564353
28	Non Return Valve Assembly	See <b>Figure 26</b>		
29	Vac Pump Drive Assembly	See <b>Figure 29</b>		
30	Priming Tank Assembly	See <b>Figure 33</b>		See <b>Figure 32</b>
31	Bearing/Shaft Assembly	See <b>Figure 22</b>		See <b>Figure 21</b>

<i>Sykes Pumps</i>	Ref.No.SY381-4	Issue Status: seventh
OPERATION& MAINTENANCE INSTRUCTIONS	Page 50 of 87	
STANDARD RANGE TRAILER MOUNTED PUMPS	Issued : 9 July	

<b>2 Wheel High Speed Trailer General Arrangement</b>				<b>Cont'd</b>
<b>Item</b>	<b>Description</b>	<b>GP150M/25</b>	<b>GP150M/60</b>	<b>GP100M/25</b>
32	Pressure Seal Assembly	See <b>Figure 23</b>		
33	Impeller/Wear Plate Assembly	See <b>Figure 25</b>		See <b>Figure 24</b>
34	Sump/Tee Assembly	See <b>Figure 41</b>		See <b>Figure 40</b>
35	Packer	SY9519553	SY9519553	SY9519553
36	Coalescer Assembly	See <b>Figure 34</b>		
37	Battery	SY7004394	SY7004394	SY7004394
38	Cable	SY3864065	SY3864065	SY3864065
39	Cable	SY3872001	SY3872001	SY3872001
40	Lug Ring	SY3864066	SY3864066	SY3864066
41	Lug Ring	SY3864067	SY3864067	SY3864067
42	Set Screw Soc	SY9519555	SY9519555	SY9519555
43	Flat Washer	SY9519556	SY9519556	SY9519556
44	Battery Terminal	SY3864068	SY3864068	SY3864068
45	Battery Terminal	SY3864069	SY3864069	SY3864069
46	Chassis Assembly	See <b>Figure 37</b>		
47	Timing Belt	SY3824029	SY3834181	SY3824029
48	Vac. Drive Guard Adaptor Plates	--	--	SY9519550
49	Bolt	--	--	SY9509552
50	Bolt	--	--	SY9519599

<i>Sykes Pumps</i>	Ref.No.SY381-4	Issue Status: seventh
OPERATION& MAINTENANCE INSTRUCTIONS	Page 51 of 87	
STANDARD RANGE TRAILER MOUNTED PUMPS	Issued : 9 July	

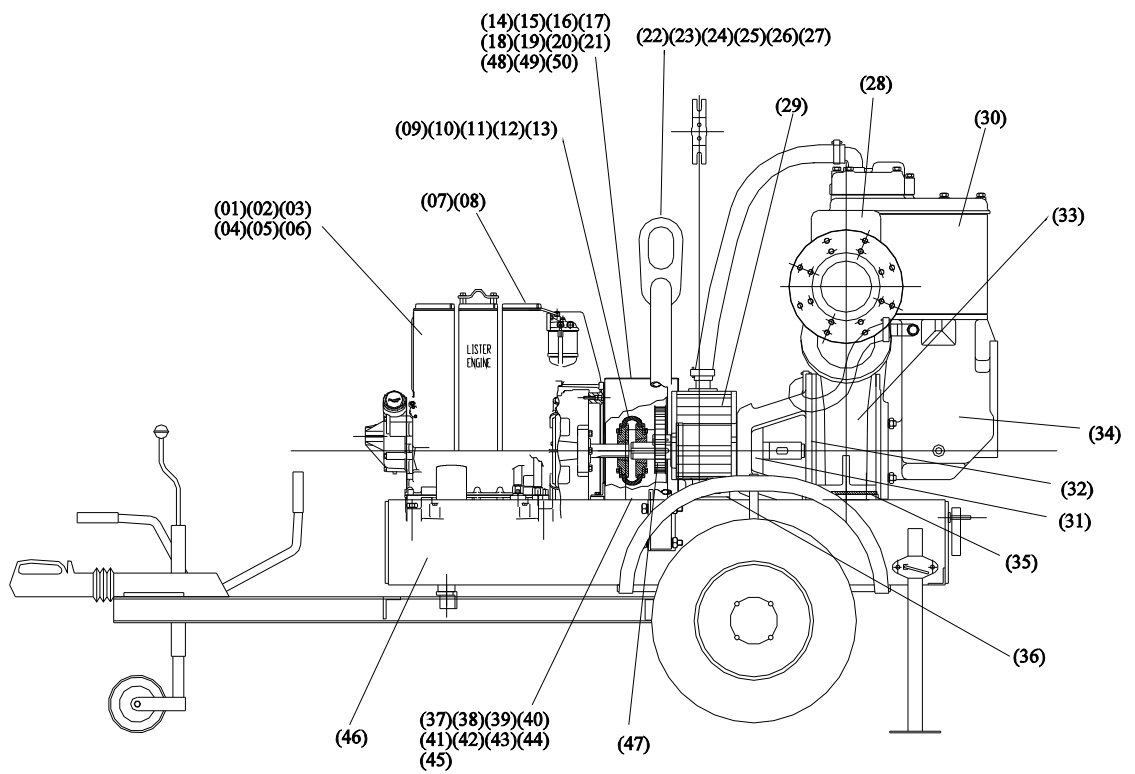
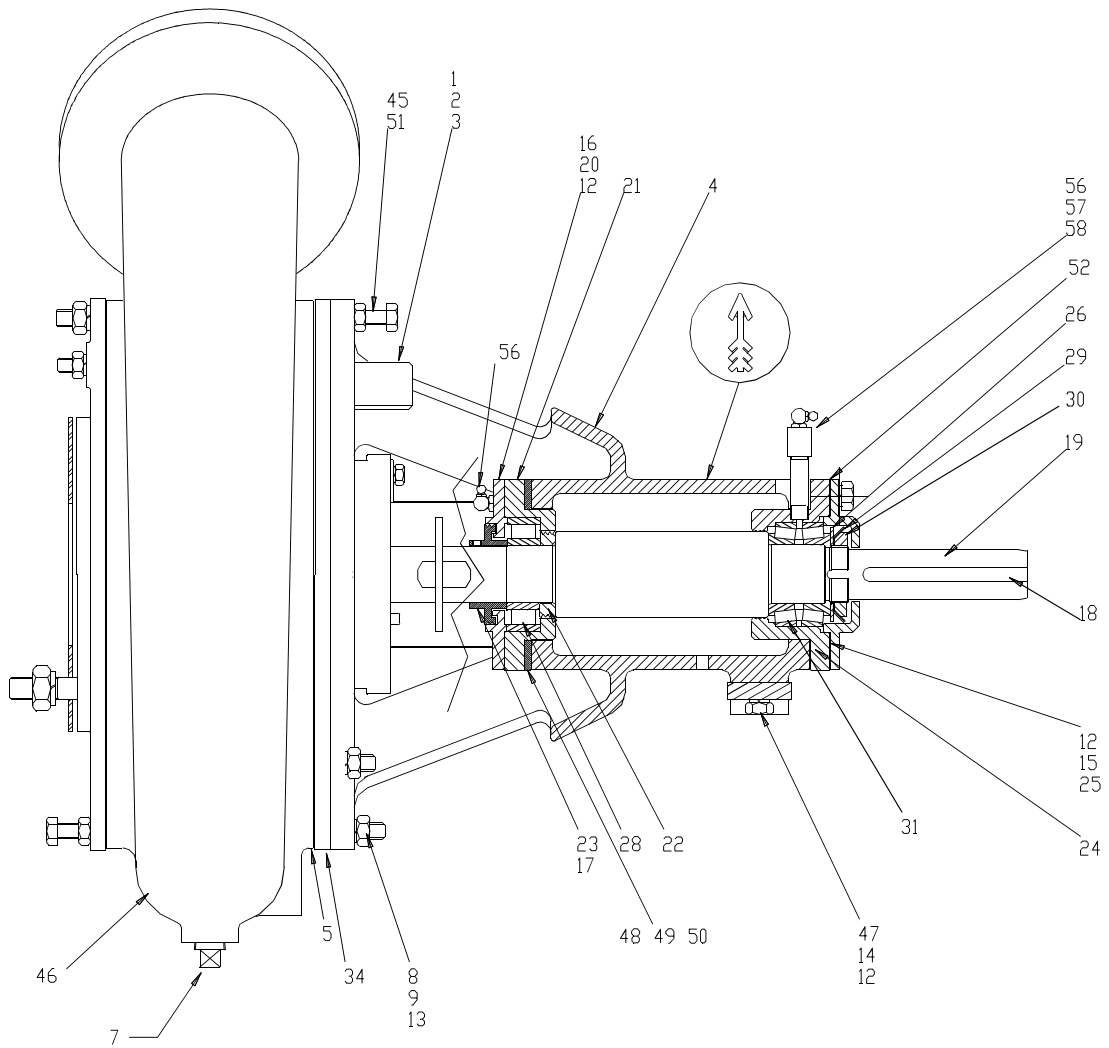

**Figure 20 G.A. 2-Wheel High Speed Trailer**

<i>Sykes Pumps</i>	Ref.No.SY381-4	Issue Status: seventh
OPERATION& MAINTENANCE INSTRUCTIONS	Page 52 of 87	
STANDARD RANGE TRAILER MOUNTED PUMPS	Issued : 9 July	

<b>Bearing/Shaft Assembly - GP100M &amp; WP150</b>					
<b>GP100M &amp; WP150</b>					
<b>Ref</b>	<b>Description</b>	<b>Part No</b>	<b>Ref</b>	<b>Description</b>	<b>Part No</b>
1	Pipe Adaptor	SY3734296	26	Grease Retainer - Drive End	SY3804114
2	Super Clamps	SY3804409	28	Bearing - Pump End	SY3804116
3	Vacuum Hose	SY3804408	29	Lock Washer - Drive End	SY3804117
4	Bearing Housing	SY3814207	30	Lock Nut - Drive End	SY3804118
5	Gasket	SY5004305	31	Bearing - Drive End	SY3804119
7	Plug Mal 1/2" Hollow	SY9209162	34	Back Cover Plate	SY3814109
8	Stud M12	SY9509134	46	Volute	SY3814143
9	Nut M12	SY9509654	47	Bracket - Bearing Housing	SY3814079
12	Spring Washer M10	SY9509807	48	Shim 0.5mm	SY3804115
13	Spring Washer M12	SY9509808	49	Shim 1.0mm	SY3804139
14	Set Screw M10 x 30	SY9519121	50	Shim 0.25mm	SY3804169
15	Set Screw M10 x 40	SY9519122	51	Nut M8	SY9509652
16	Set Screw M10 x 50	SY9519124	52	Shim - Bearing Housing/End Cap	SY3804366
17	Set Screw M6	SY9529333	56	Grease Nipple	SY9219010
18	Key- Pump Shaft	SY3804096	57	Socket 1/8" BSP	SY9209260
19	Shaft	SY3804107	58	Steel Barrel Nipple	SY9209512
20	End Cap Pump End	SY3804406			
21	Bearing Housing - Pump End	SY3804109			
22	Bearing Spacer - Pump End	SY3804110			
23	Grease Retainer - Pump End	SY3804111			
24	Bearing Housing - Drive End	SY3804407			
25	Bearing End Cap - Drive End	SY3804113			

<b>Sykes Pumps</b>	Ref.No.SY381-4	Issue Status: seventh
OPERATION & MAINTENANCE INSTRUCTIONS	Page 53 of 87	
STANDARD RANGE TRAILER MOUNTED PUMPS	Issued : 9 July	

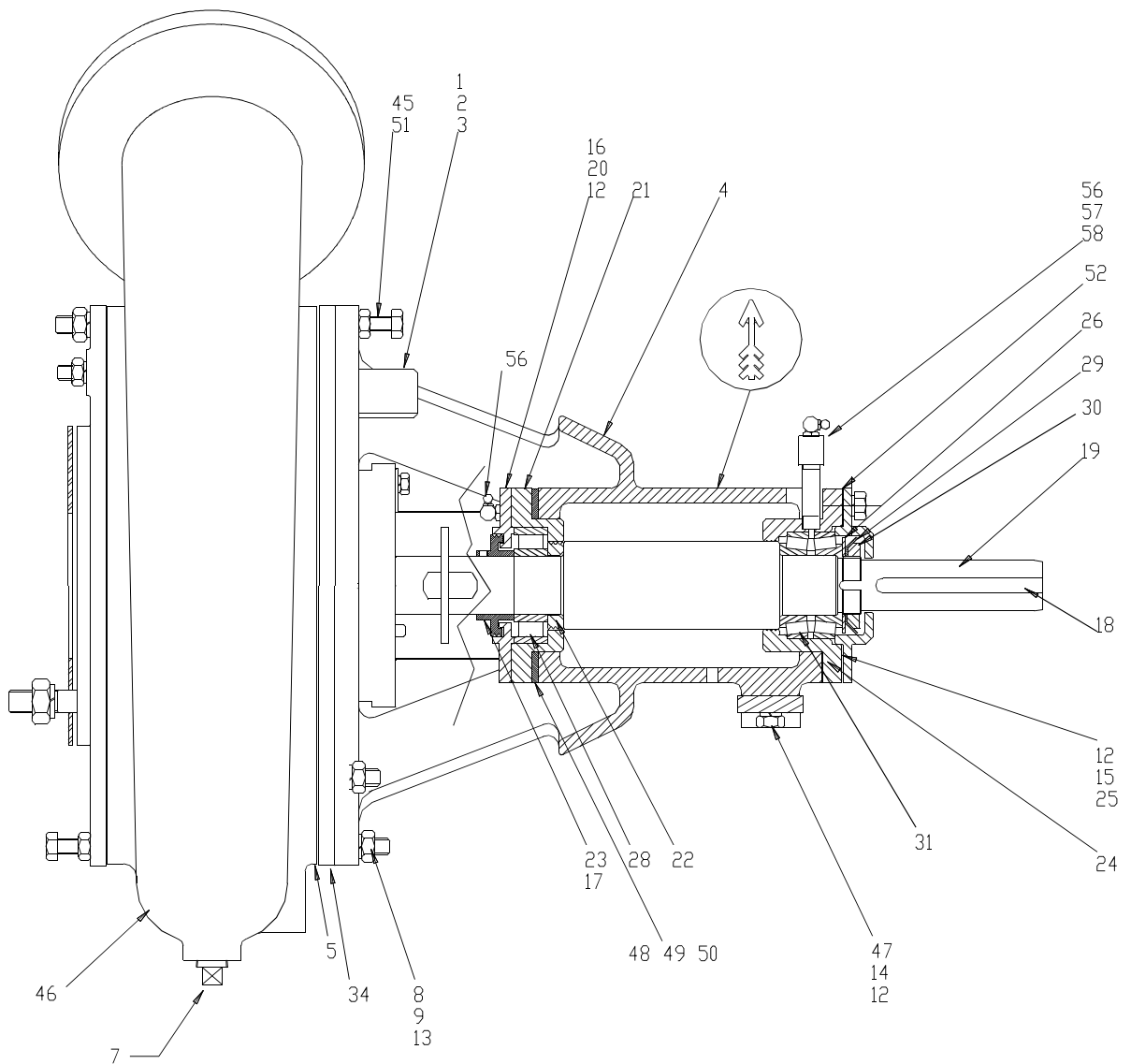

**Figure 21** Bearing/Shaft Assembly - WP150 & GP100M

<b>Sykes Pumps</b>	Ref.No.SY381-4	Issue Status: seventh
OPERATION& MAINTENANCE INSTRUCTIONS	Page 54 of 87	
STANDARD RANGE TRAILER MOUNTED PUMPS	Issued : 9 July	

<b>Bearing/Shaft Assembly - GP150M &amp; GP200</b>					
<b>GP150M &amp; GP200</b>					
<b>Ref</b>	<b>Description</b>	<b>Part No</b>	<b>Ref</b>	<b>Description</b>	<b>Part No</b>
1	Pipe Adaptor	SY3734296	26	Grease Retainer - Drive End	SY3834121
2	Super Clamps	SY3804409	28	Bearing - Pump End	SY3834117
3	Vacuum Hose	SY3804408	29	Lock Washer - Drive End	SY3834126
4	Bearing Housing	SY3834242	30	Lock Nut - Drive End	SY3834125
5	Gasket	SY5004318	31	Bearing - Drive End	SY3834122
7	Plug Mal 1/2" Hollow	SY9209162	34	Back Cover Plate	SY3834139-2
8	Stud M12-M16	SY9509214	45	Set Screw M10 x 50	SY9519124
9	Nut M12-M16	SY9509656	46	Volute	SY3834169
12	Spring Washer M10	SY9509807	47	Bracket - Bearing Housing	SY3814079
13	Spring Washer M16	SY9509810	48	Shim 0.5mm	SY3834116
14	Set Screw M10 x 35	SY9519121	49	Shim 1.0mm	SY3834131
15	Set Screw M10 x 40	SY9519122	50	Shim 0.25mm	SY3834140
16	Set Screw M10 x 50	SY9519124	51	Nut M10	SY9509653
17	Set Screw M6x6	SY9529333	52	Shim - Bearing Housing/End Cap	SY3834223
18	Key- Pump Shaft	SY3834103	56	Grease Nipple	SY9219010
19	Shaft	SY3834118	57	Socket 1/8" BSP	SY9209260
20	End Cap Pump End	SY3834244	58	Steel Barrel Nipple	SY9209512
21	Bearing Housing - Pump End	SY3834115			
22	Bearing Spacer - Pump End	SY3834120			
23	Grease Retainer - Pump End	SY3834119			
24	Bearing Housing - Drive End	SY3834243			
25	Bearing End Cap - Drive End	SY3834124			

<i>Sykes Pumps</i>	Ref.No.SY381-4	Issue Status: seventh
OPERATION & MAINTENANCE INSTRUCTIONS	Page 55 of 87	
STANDARD RANGE TRAILER MOUNTED PUMPS	Issued : 9 July	



**Figure 22** Bearing/Shaft Assembly - GP150M & GP200

<i>Sykes Pumps</i>	Ref.No.SY381-4	Issue Status: seventh
OPERATION& MAINTENANCE INSTRUCTIONS	Page 56 of 87	
STANDARD RANGE TRAILER MOUNTED PUMPS	Issued : 9 July	

<b>Pressure Seal Assembly</b>					
<b>GP100M &amp; WP150</b>			<b>GP150M &amp; GP200</b>		
<b>Ref</b>	<b>Description</b>	<b>Part No</b>	<b>Ref</b>	<b>Description</b>	<b>Part No</b>
6	1/2" Gland Packing	SY6384003A	6	1/2" Gland Packing	SY6384003A
10	Spring Washer M4	SY9509803	10	Spring Washer M4	SY9509803
11	Spring Washer M8	SY9509806	11	Spring Washer M8	SY9509806
32	Screw Csk M6	SY9529365	32	Screw Csk M6	SY9529365
33	Guard	SY3804313	33	Guard	SY3804313
35	Compression Spring	SY3804160	35	Compression Spring	SY3804160
36	Retaining Ring (Univac)	SY3964005	36	Retaining Ring (Univac)	SY3964005
37	End Cap for Seal Assy	SY3962002	37	End Cap for Seal Assy	SY3962002
38	O-Ring	SY3804166	38	O-Ring	SY3804166
42	Screw/Cap M4	SY9529204	42	Screw/Cap M4	SY9529204
43	Packing Carrier	SY3804168-2	43	Packing Carrier	SY3804168-2
45	Set Screw M8	SY9519104	45	Set Screw M8	SY9519104
40	Gasket Back Cover	SY5004410	40	Gasket Back Cover	SY5004410
55	Liquid Thrower	SY3804404	55	Liquid Thrower	SY3834241
59	Spring Gaitor	SY3804412	59	Spring Gaitor	SY3804412



<i>Sykes Pumps</i>	Ref.No.SY381-4	Issue Status: seventh
OPERATION& MAINTENANCE INSTRUCTIONS	Page 57 of 87	
STANDARD RANGE TRAILER MOUNTED PUMPS	Issued : 9 July	

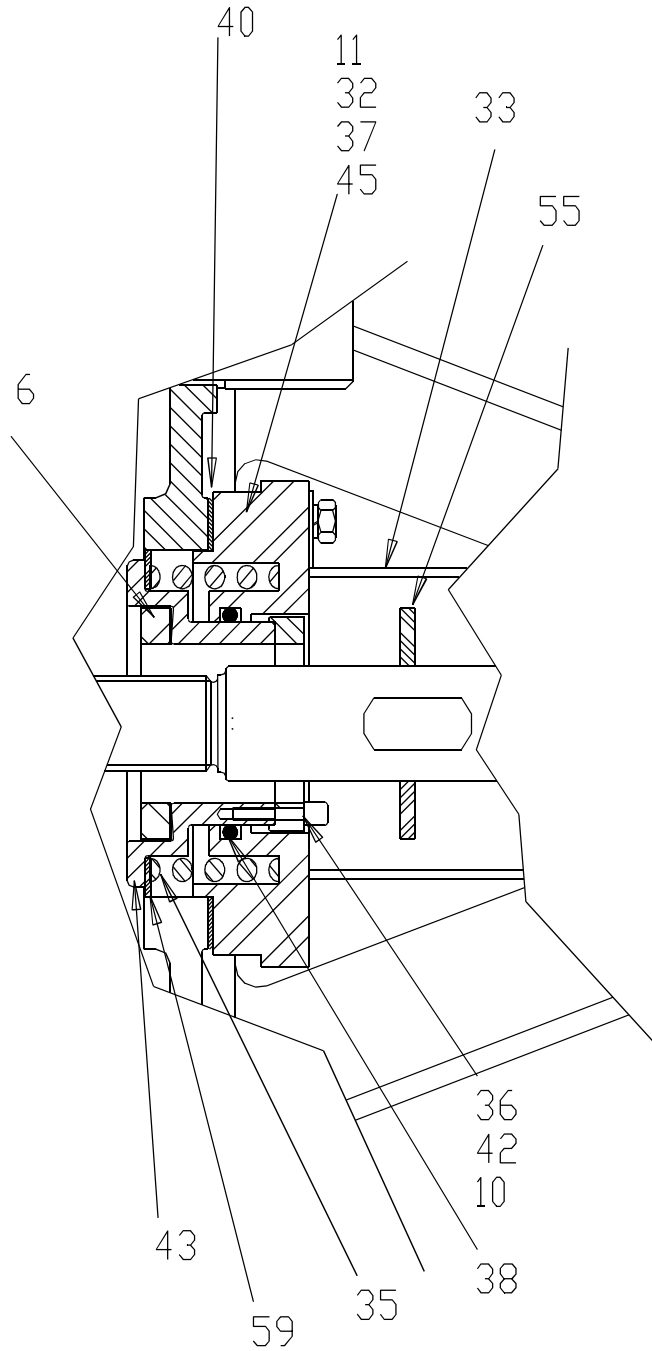

**Figure 23** Pressure Seal Assembly

<b>Sykes Pumps</b>	Ref.No.SY381-4	Issue Status: seventh
OPERATION& MAINTENANCE INSTRUCTIONS	Page 58 of 87	
STANDARD RANGE TRAILER MOUNTED PUMPS	Issued : 9 July	

<b>Impeller/Wear Plate Assembly - GP100M &amp; WP150</b>					
<b>GP100M</b>			<b>WP150</b>		
<b>Ref</b>	<b>Description</b>	<b>Part No</b>	<b>Ref</b>	<b>Description</b>	<b>Part No</b>
1	Front Cover Plate	SY3734147	1	Front Cover Plate	SY3824060
2 *	Front Wear Plate	SY3814142	2 *	Front Wear Plate	SY3824053
3 *	Impeller Assembly	SY3814137	3 *	Impeller Assembly	SY3824052
3A	Wear Ring - Impeller	SY3804017	3a	Wear Ring - Impeller	SY3804017
3B	Sleeve - Impeller	SY3804413	3b	Sleeve - Impeller	SY3804413
4 *	Back Wear Plate	SY3814138	4 *	Back Wear Plate	SY3824054
5	Shim, Copper Impeller	SY3804122	5	Shim, Copper Impeller	SY3804122
6	Gasket/Shim 1.0mm	SY5004305	6	Gasket/Shim 1.0mm	SY5004305
7	Gasket/Shim 0.5mm	SY5004306	7	Gasket/Shim 0.5mm	SY5004306
8	Gasket/Shim 0.25mm	SY5004307	8	Gasket/Shim 0.25mm	SY5004307
9	Label	SY2554048	9	Label	SY2554048
10	Set Screw M10 x 40	SY9519122	10	Set Screw M8 x 40	SY9519102
11	Stud M10 x 45	SY9509094	11	Stud M10 x 45	SY9509094
12	Stud M10 x 40	SY9509093	12	Stud M10 x 40	SY9509093
13	Stud M12 x 30	SY9509129	13	Stud M12 x 30	SY9509129
14	Stud M16 x 45	SY9509214	14	Stud M16 x 45	SY9509214
15	Washer M10	SY9509679	15	Washer M10	SY9509679
16	Spring Washer M12	SY9509808	16	Spring Washer M12	SY9509808
17	Spring Washer M16	SY9509810	17	Spring Washer M16	SY9509810
18	Nut M10	SY9509653	18	Nut M8	SY9509652
19	Nut M10	SY9509653	19	Nut M10	SY9509653
20	Nut M12	SY9509654	20	Nut M12	SY9509654
21	Nut M16	SY9509656	21	Nut M16	SY9509656
22	Washer/Sealing M10	SY5004308	22	Washer/Sealing M10	SY5004308
23	Guard	SY3804313	23	Guard	SY3804313
24	Joint	SY5004121	24	Joint	SY5004106

\* = Options Available (See Page 86)

<b>Sykes Pumps</b>	Ref.No.SY381-4	Issue Status: seventh
OPERATION & MAINTENANCE INSTRUCTIONS	Page 59 of 87	
STANDARD RANGE TRAILER MOUNTED PUMPS	Issued : 9 July	

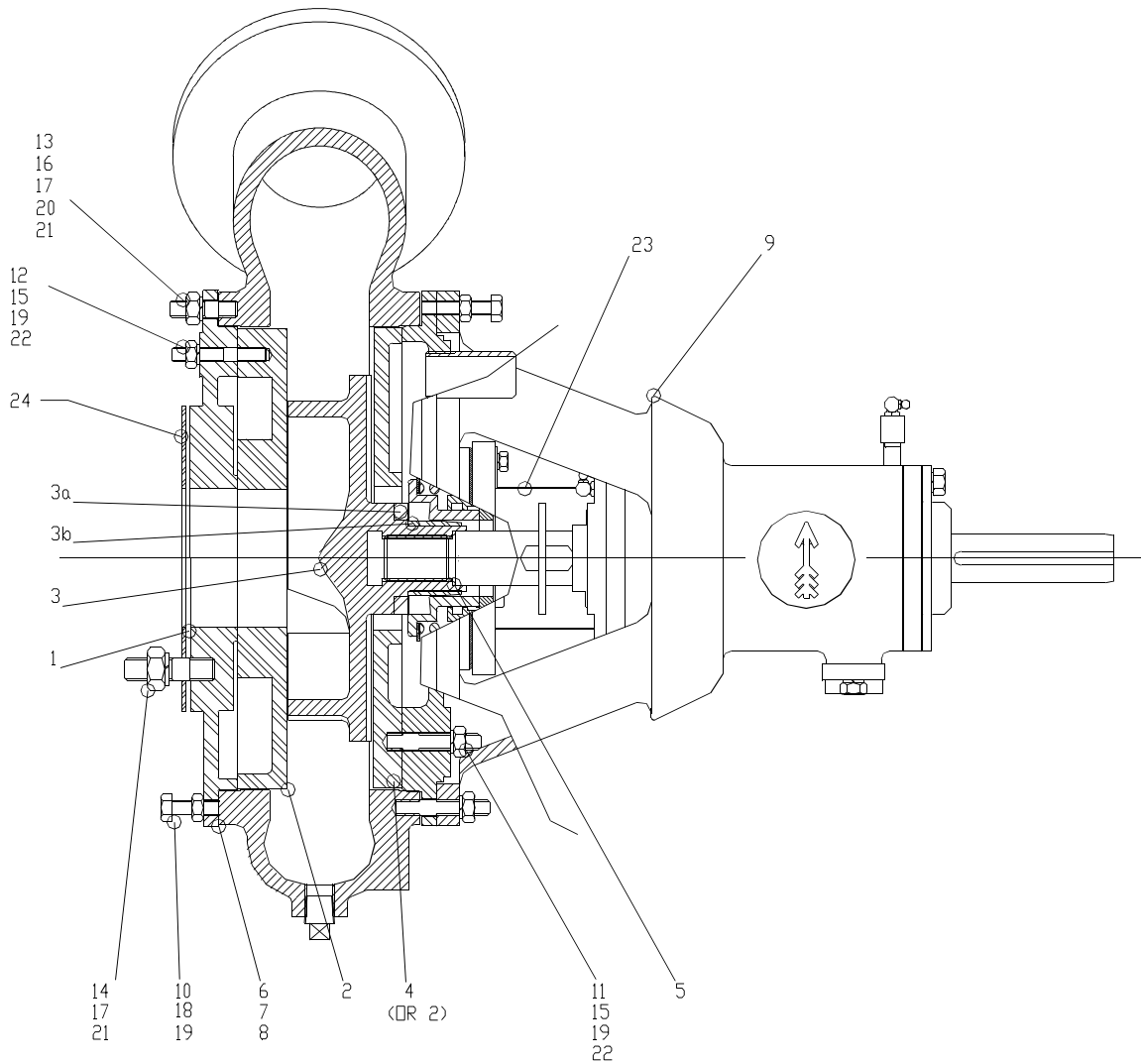

**Figure 24** Impeller/Wear Plate Assembly - WP150 & GP100M

<b>Sykes Pumps</b>	Ref.No.SY381-4	Issue Status: seventh
OPERATION& MAINTENANCE INSTRUCTIONS	Page 60 of 87	
STANDARD RANGE TRAILER MOUNTED PUMPS	Issued : 9 July	

<b>Impeller/Wear Plate Assembly - GP150M &amp; GP200</b>					
<b>GP150M</b>			<b>GP200</b>		
<b>Ref</b>	<b>Description</b>	<b>Part No</b>	<b>Ref</b>	<b>Description</b>	<b>Part No</b>
1	Front Cover Plate	SY3744028	1	Front Cover Plate	SY3744238
2 *	Front Wear Plate	SY3834191	2 *	Front Wear Plate	SY3844059
3 *	Impeller Assembly	SY3834171	3 *	Impeller Assembly	SY3844058
3a	Wear Ring - Impeller	SY3804017	3A	Wear Ring - Impeller	SY3804017
3b	Sleeve - Impeller	SY3804413	3B	Sleeve - Impeller	SY3804413
4 *	Back Wear Plate	SY3834166	4 *	Back Wear Plate	SY3834166
5	Shim, S/Steel Impeller	SY3834127	5	Shim, Copper Impeller	SY3834127
6	Gasket/Shim 1.0mm	SY5004316	6	Gasket/Shim 1.0mm	SY5004316
7	Gasket/Shim 0.5mm	SY5004317	7	Gasket/Shim 0.5mm	SY5004317
8	Gasket/Shim 0.25mm	SY5004318	8	Gasket/Shim 0.25mm	SY5004318
9	Label	SY2554048	9	Label	SY2554048
10	Set Screw M10 x 40	SY9519122	10	Set Screw M10 x 40	SY9519122
11	Stud M10 x 55	SY9509096	11	Stud M10 x 55	SY9509096
12	-	-	12	-	-
13	Stud M16 x 35	SY9509210	13	Stud M16 x 35	SY9509210
14	Stud M16 x 45	SY9509214	14	Stud M16 x 45	SY9509214
15	Washer M10	SY9509679	15	Washer M10	SY9509679
16	-	-	16	-	-
17	Spring Washer M16	SY9509810	17	Spring Washer M16	SY9509810
18	-	-	18	-	-
19	Nut M10	SY9509653	19	Nut M10	SY9509653
20	-	-	20	-	-
21	Nut M16	SY9509656	21	Nut M16	SY9509656
22	Washer/Sealing M10	SY5004308	22	Washer/Sealing M10	SY5004308
23	Guard	SY3804313	23	Guard	SY3804313
24	Joint	SY5004106	24	Joint	SY5004113

\* = Option Available (See Page 86)

<b>Sykes Pumps</b>	Ref.No.SY381-4	Issue Status: seventh
OPERATION & MAINTENANCE INSTRUCTIONS	Page 61 of 87	
STANDARD RANGE TRAILER MOUNTED PUMPS	Issued : 9 July	

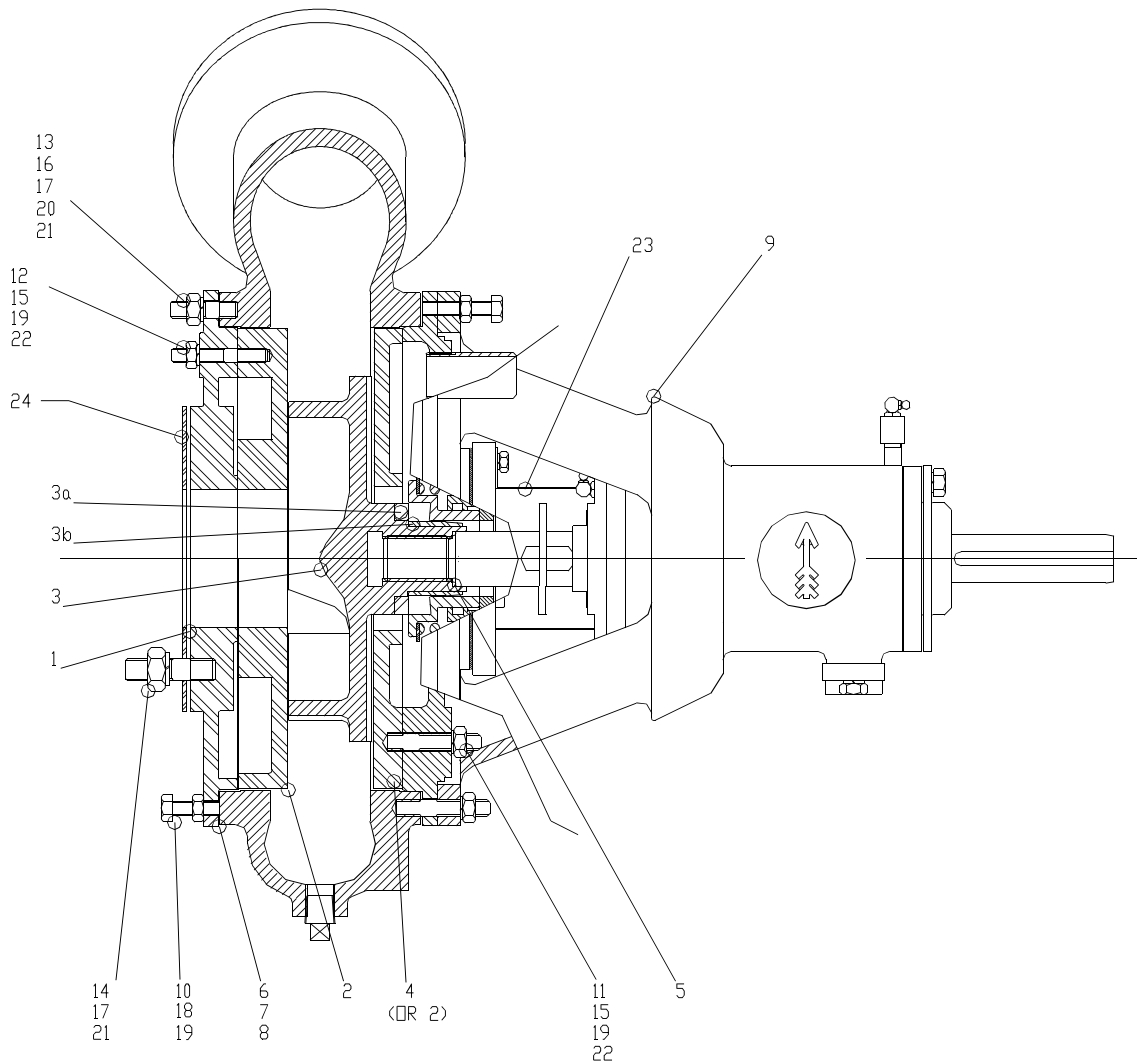
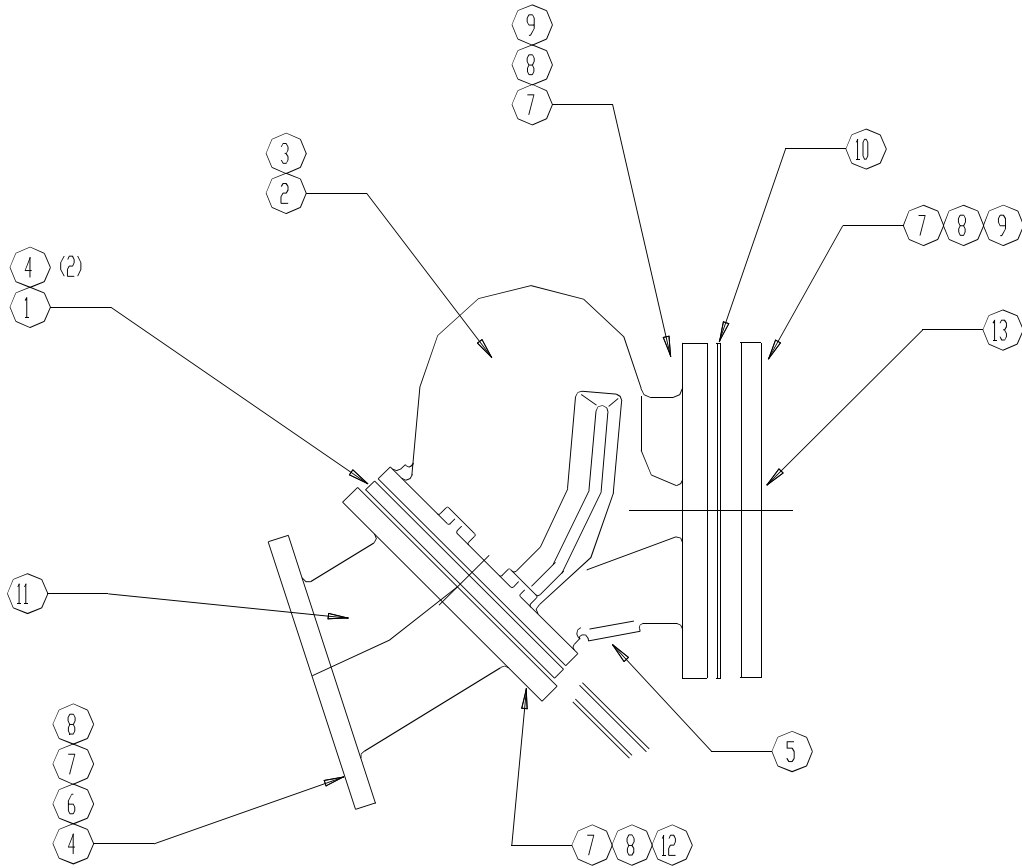

**Figure 25** Impeller/Wear Plate Assembly - GP150M & GP200

<b>Sykes Pumps</b>	Ref.No.SY381-4	Issue Status: seventh
OPERATION& MAINTENANCE INSTRUCTIONS	Page 62 of 87	
STANDARD RANGE TRAILER MOUNTED PUMPS	Issued : 9 July	

<b>Non Return Valve Assembly</b>					
<b>GP100M</b>			<b>GP150M</b>		
<b>Ref</b>	<b>Description</b>	<b>Part No</b>	<b>Ref</b>	<b>Description</b>	<b>Part No</b>
1	Valve Seat	SY3814222	1	Valve Seat	SY3814223
2	Ball Reflux 120mm	SY3814226	2	Ball Reflux 180mm	SY3834248
3	Valve Body	SY3824086	3	Valve Body	SY3844080
4	Gasket	SY5004430	4	Gasket	SY5004431
5	Plug 1"BSP	SY9209164	5	Plug 1"BSP	SY9209164
6	Bolt Hex M16 x 70	SY9509585	6	Bolt Hex M16 x 70	SY9509585
7	Nut Hex M16	SY9509656	7	Nut Hex M16	SY9509656
8	Spring Washer M16	SY9509810	8	Spring Washer M16	SY9509810
9	Stud M16 x 45	SY9509214	9	Stud M16 x 45	SY9509214
10	Joint - Adaptor Plate	SY5004106	10	Joint - Adaptor Plate	SY5004113
11	Adaptor Bend	SY3814229	11	Adaptor Bend	SY3834251
12	Stud M16 x 50	SY9509215	12	Stud M16 x 60	SY9509217
13	Adaptor Plate	SY3814160	13	Adaptor Plate	SY3834197
<b>WP150</b>			<b>GP200</b>		
1	Valve Seat	SY3814222	1	Valve Seat	SY3814223
2	Ball Reflux 120mm	SY3814226	2	Ball Reflux 180mm	SY3834248
3	Valve Body	SY3824086	3	Valve Body	SY3844080
4	Gasket	SY5004430	4	Gasket	SY5004431
5	Plug 1"BSP	SY9209164	5	Plug 1"BSP	SY9209164
6	Bolt Hex M16 x 70	SY9509585	6	Bolt Hex M16 x 70	SY9509585
7	Nut Hex M16	SY9509656	7	Nut Hex M16	SY9509656
8	Spring Washer M16	SY9509810	8	Spring Washer M16	SY9509810
11	Adaptor Bend	SY3814229	11	Adaptor Bend	SY3834251
12	Stud M16 x 55	SY9509216	12	Stud M16 x 60	SY9509217

<b>Sykes Pumps</b>	Ref.No.SY381-4	Issue Status: seventh
OPERATION& MAINTENANCE INSTRUCTIONS	Page 63 of 87	
STANDARD RANGE TRAILER MOUNTED PUMPS	Issued : 9 July	



**Figure 26** Non Return Valve Assembly

<i>Sykes Pumps</i>	Ref.No.SY381-4	Issue Status: seventh
OPERATION& MAINTENANCE INSTRUCTIONS	Page 64 of 87	
STANDARD RANGE TRAILER MOUNTED PUMPS	Issued : 9 July	

<b>Vacuum Pump Drive Assembly</b>					
<b>Item</b>	<b>Description</b>	<b>GP100M x 25</b>	<b>WP150 x 60</b>	<b>GP150M x 60 &amp; GP200 x 60</b>	<b>GP150M X 25 &amp; GP200 X 25</b>
1	Vacuum Pump	SY6671002	SY6681003	SY6681003	SY6671002-1
2	Adaptor Plate	SY3814151	SY3834178	SY3834178	SY3814151
3	Spacer Bearing	SY3804283	SY3804283	-	-
4	Hose	SY3804356	SY3804355	SY3804355	SY3804408
5	Pulley	SY3834105	SY3834180	SY3834180	SY3834105
6	Drive Belt	SY3824029	SY3834181	SY3834181	SY3824029
7	Pulley	SY3834184	SY3804295	SY3834182	SY3834182
8	Taper Bush	SY9059149	SY9059178	SY9059178	SY9059149
9	Taper Bush	SY9059153	SY9059153	SY9059184	SY9059184
10	Joint ADT + VP	SY5004200	SY5004170	SY5004170	SY5004200
11	Joint Bend + VP	SY5004173	SY5004174	SY5004174	SY5004173
12	Adaptor	SY3554113	SY3834002	SY3834002	SY3964039
13	Hex Bush	-	SY9209079	SY9209079	-
14	Pipe Adaptor	SY3474599	SY3734296	SY3734296	SY3734296
15	Elbow	SY9209044	SY9209045	SY9209045	SY9209044
16	Adaptor	-	SY9519575	SY9519575	-
17	Bush	-	SY9519576	SY9519576	-
18	Elbow	SY9209040	-	-	SY9209040
19	Stud	SY9509089	SY9509091	SY9509091	SY9505089
20	Washer	SY9519578	SY9519578	SY9519578	SY9519578
21	Elbow	-	SY9209041	SY9209041	-
22	Nut	SY9509653	SY9509865	SY9509865	SY9509653
23	Bolt	SY9519579	SY9519579	SY9519122	-
24	Washer		SY9519578	SY9519578	-
25	Spring Washer	SY9509807	SY9509807	SY9509807	SY9509807
26	Jubilee Clip	SY4004041	SY4004041	SY4004041	SY4004041
27	Bush	SY9209069	-	-	SY9209069
28	Elbow	-	SY9209340	SY9209340	-
29	Nipple	SY9519577	-	-	SY9519577



<b>Sykes Pumps</b>	Ref.No.SY381-4	Issue Status: seventh
OPERATION& MAINTENANCE INSTRUCTIONS	Page 65 of 87	
STANDARD RANGE TRAILER MOUNTED PUMPS	Issued : 9 July	

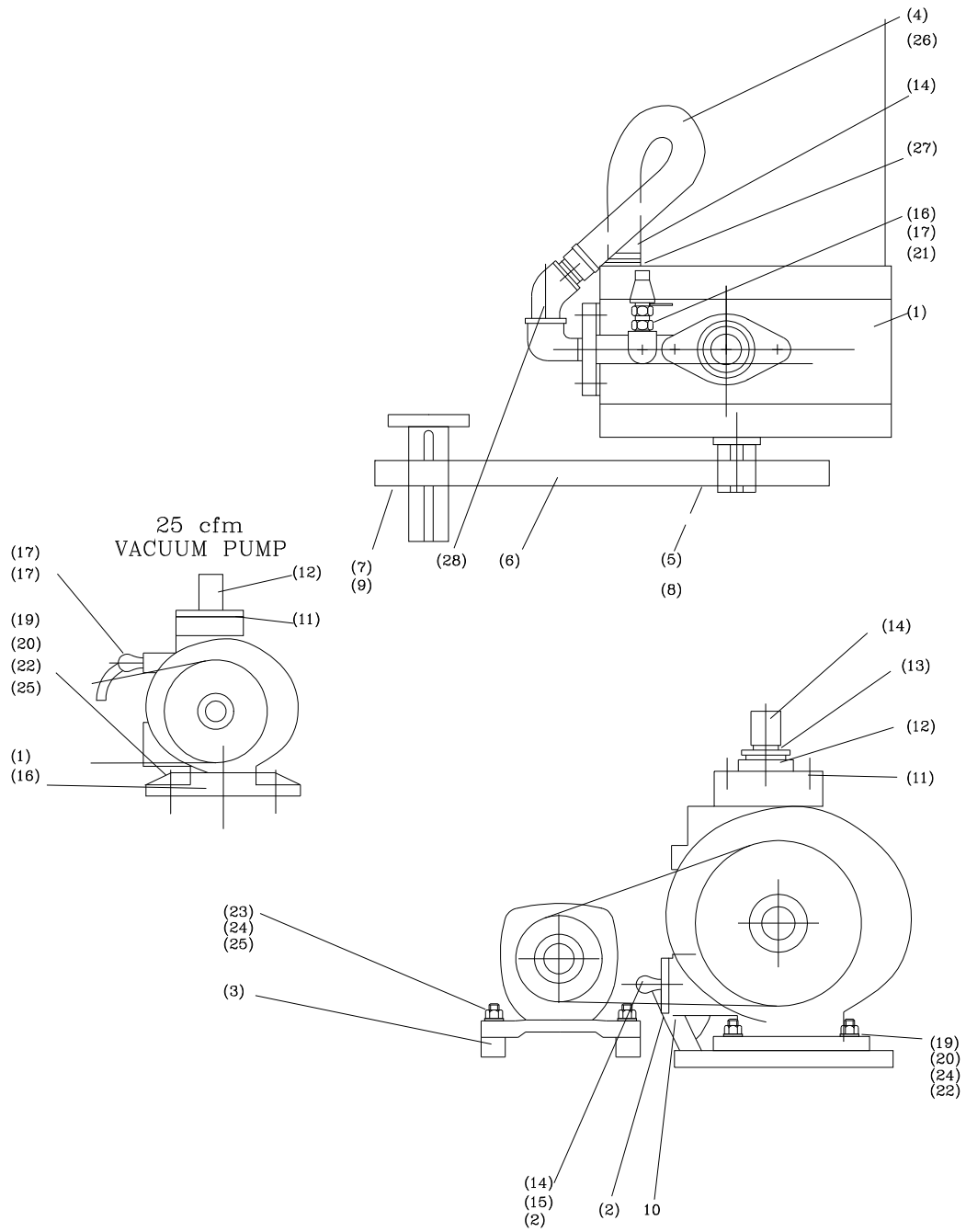

**Figure 27 - Vacuum Pump - Drives and Fittings**

<i>Sykes Pumps</i>	Ref.No.SY381-4	Issue Status: seventh
OPERATION& MAINTENANCE INSTRUCTIONS	Page 66 of 87	
STANDARD RANGE TRAILER MOUNTED PUMPS	Issued : 9 July	

FL25 25 cfm Vacuum Pump							
Item	Description	Qty	Part No	Item	Description	Qty	Part No
U10	Drive key	1	SY6674034	U33	Bearing cover-Plate joint	1	SY6674040
U11	Retaining dowel	1	SY6674033	U34	Bearing cover-plate screw	3	SY6674038
U12	Grub screw	2	SY6674043	U35	Bearing cover-plate	1	SY6674045
U13	End cover washer	8	SY6674041	U36	Plug, 1/8" BSP	1	SY6674039
U14	End cover screw	8	SY9539087	U39	Non-drive end cover	1	SY6674030
U15	Drive end oil seal	1	SY6674042	U41	Inlet flange nut	2	SY9509652
U16	Bearing retaining circlip	4	SY6674037	U42	Inlet flange washer	2	SY9509678
U17	Bearing	2	SY6674044	U43	Inlet flange joint	1	SY5004173
U19	Drive end cover	1	SY6674029	U44	Inlet flange stud	2	SY9509055
U20	'O'-ring	2	SY6674007	U45	Inlet check valve	1	SY6662001
U21	End cover dowel	4	SY6684013	U46	Inlet check valve joint	1	SY6684023
U22	Rotor	1	SY6674031	U47	Stator (housing)	1	SY6674032
U28	Outlet flange stud	2	SY9509047	U48	Oil-hole 'O'-ring	2	SY6674017
U29	Outlet flange nut	2	SY9509652	U49	Rotor blade	4	SY6674002
U30	Outlet flange washer	2	SY9509678				

SP25 Vacuum Priming Pump					
Ref.	Description	Part No.	Ref.	Description	Part No.
1	Cylinder	US10142	9	Seal	UF1046
2	Coverplate-Drive End	US13032/1	10	Thrust Washer	UB1110
3	Coverplate-Rear End	US13032/2	11	O Ring	UF1232
4	Rotor & Shaft Assembly	US10136	12	Dowel	UE1000
5	Spacing Ring	US10133	13	Hex Head Screw	UG1014
6	Foot	US10135	14	Hex Head Screw	UG1112
7	Blade	US8047/1	15	Bearing Shim	UK1012
8	Ball Bearing	UH1057		Non return Valve	SY7954004

<b>Sykes Pumps</b>	Ref.No.SY381-4	Issue Status: seventh
OPERATION & MAINTENANCE INSTRUCTIONS	Page 67 of 87	
STANDARD RANGE TRAILER MOUNTED PUMPS	Issued : 9 July	

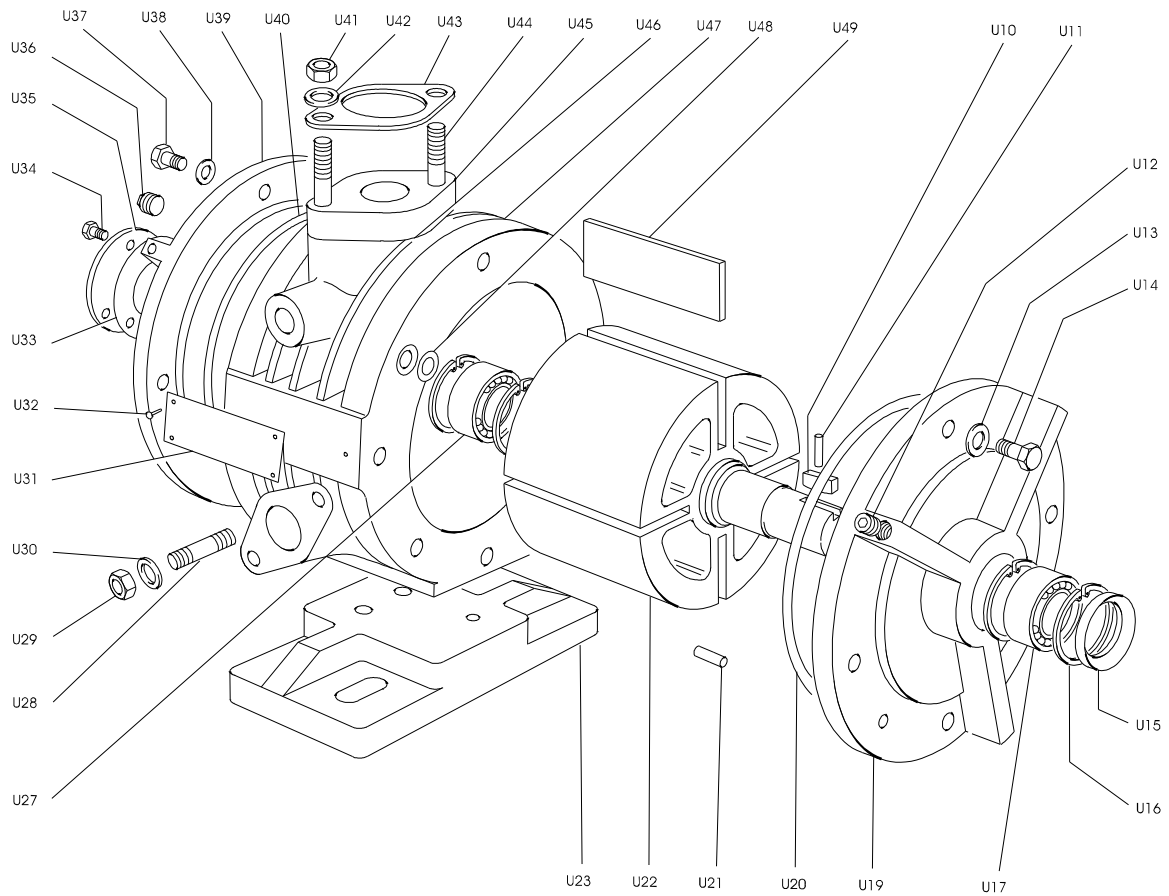

**Figure 28** FL 25cfm Vacuum Priming System

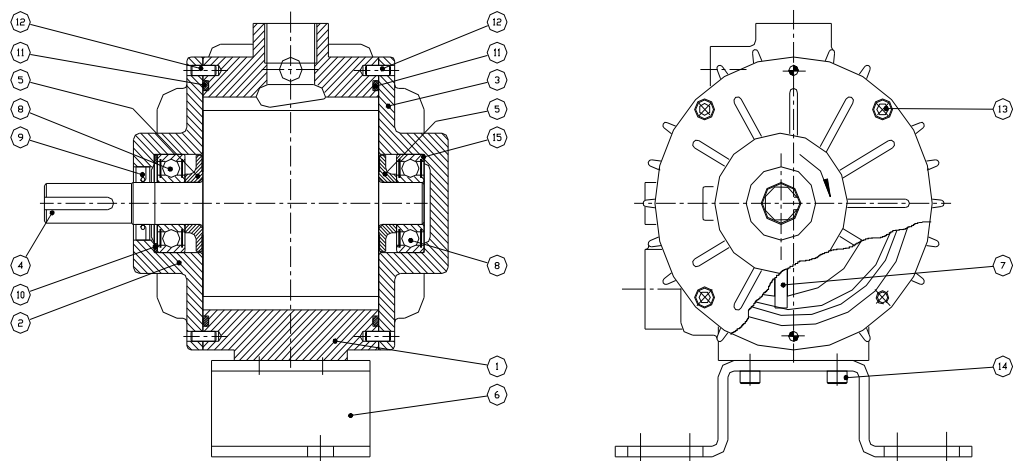

**Figure 29** SP25 cfm Vacuum Priming System

<i>Sykes Pumps</i>	Ref.No.SY381-4	Issue Status: seventh
OPERATION& MAINTENANCE INSTRUCTIONS	Page 68 of 87	
STANDARD RANGE TRAILER MOUNTED PUMPS	Issued : 9 July	

<b>FL60 Vacuum Priming Pump</b>					
Ref.	Description	Part No.	Ref.	Description	Part No.
U01	Stator (Housing)	SY668 4029	U17	Lifting Eye	SY668 4022
U02	Rotor	SY668 4009	U18	Foot	SY668 4032
U03	Cover (Non-drive End)	SY668 4030	U19	Dowel	SY668 4034
U04	Cover (drive end)	SY668 4010	U20	Screw M8×30	SY950 9520
U05	Oil Seal	SY668 4016	U21	Washer M8	SY950 9678
U06	Bearing	SY668 4020	U22	Oil Seal Retaining Plate	SY668 4033
U07	'O'Ring -Oil Hole	SY668 4017	U23	Bearing Cover Plate	SY668 4037
U08	'O'Ring -End Cover	SY668 4018	U24	Joint -Bearing Cover Plate	SY668 4035
U09	Bolt, M10×35	SY950 9535	U25	Ch. Screw M6×8	SY668 4039
U10	Washer, M10	SY950 9679	U26	Joint -Check Valve to Stator	SY668 4024
U11	Dowel	SY668 4013	U27	Studs M10×55 -Inlet Flange	SY950 9096
U12	Blade	SY668 4019	U28	Washer M10	SY950 9679
U13	Stud, M10×25	SY950 9087	U29	Nut M10	SY950 9653
U14	Legend Plate	SY668 4028	U30	Check Valve	SY668 2001
U15	Rivet	SY668 4006	U31	Joint -Flange	SY500 4174
U16	Plug, 1/8" BSP	SY920 9159			

<b>SP60 Vacuum Priming Pump</b>					
Ref.	Description	Part No.	Ref.	Description	Part No.
1	Cylinder	US13028	8	Seal	UF1044
2	Coverplate-Drive End	US13029/1	9	Thrust Washer	UB1070
3	Coverplate-Rear End	US13029/2	10	O Ring	UF1217
4	Rotor & Shaft Assembly	US8580/4	11	Dowel	UE1000
5	Spacing Ring	US8608/1	12	Hex Head Screw	UG1083
6	Blade	US8595/1	13	Bearing Shim	UK1012
7	Ball Bearing	UH1093		Non return valve	US9301

<b>Sykes Pumps</b>	Ref.No.SY381-4	Issue Status: seventh
OPERATION & MAINTENANCE INSTRUCTIONS	Page 69 of 87	
STANDARD RANGE TRAILER MOUNTED PUMPS	Issued : 9 July	

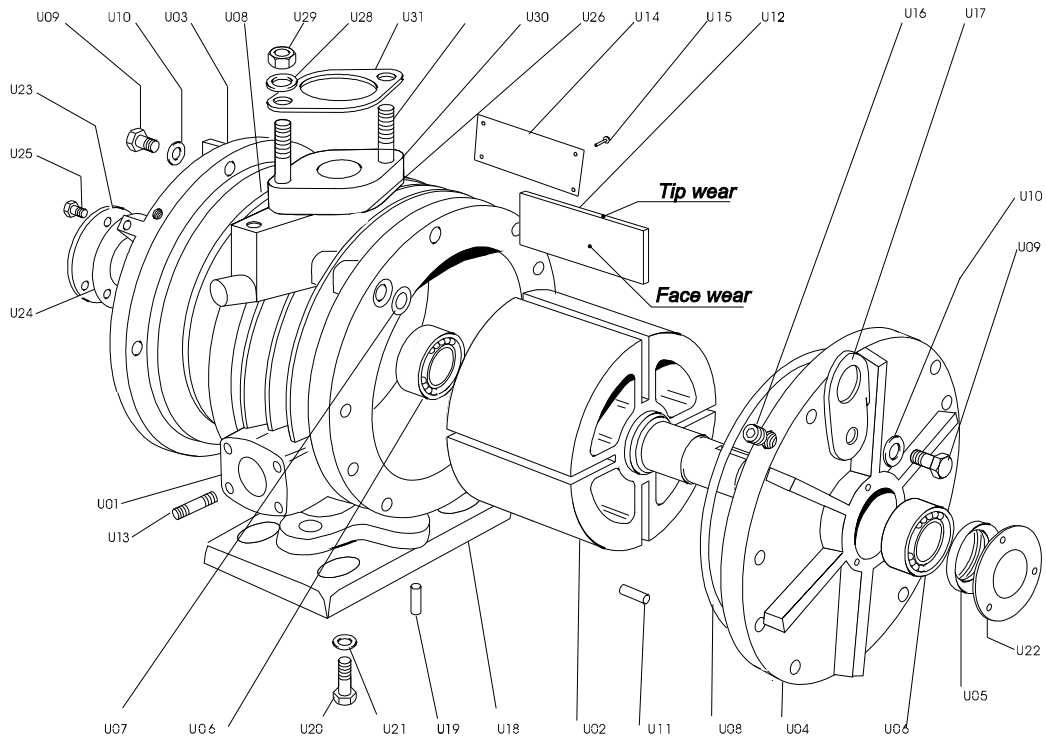

**Figure 30 FL60 Vacuum Priming Pump**

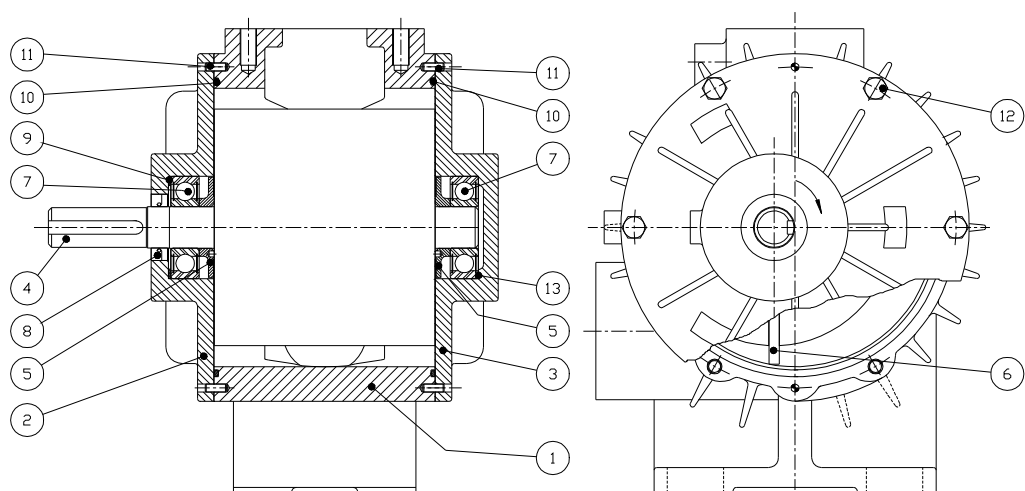
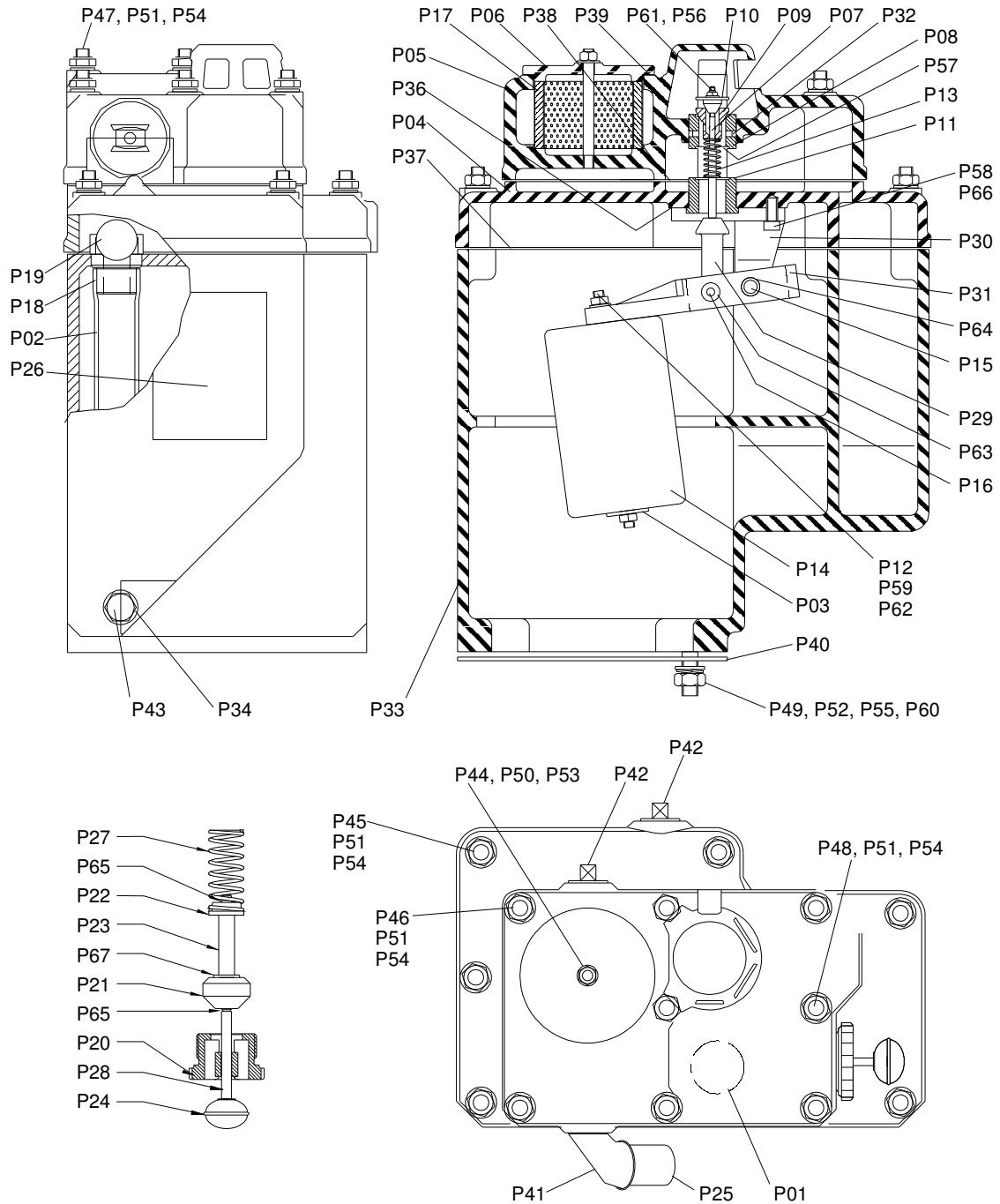

**Figure 31 SP60 Vacuum Priming Pump**

<b>Sykes Pumps</b>	Ref.No.SY381-4	Issue Status: seventh
OPERATION& MAINTENANCE INSTRUCTIONS	Page 70 of 87	
STANDARD RANGE TRAILER MOUNTED PUMPS	Issued : 9 July	

<b>25cfm Priming tank assembly</b>					
<b>Item</b>	<b>Description</b>	<b>Part No.</b>	<b>Item</b>	<b>Description</b>	<b>Part No.</b>
P01	Ball Valve	SY1544001	P36	Joint Fulcrum brk	SY5004235
P02	PVC Hose	SY3404502	P37	Tank/Top Cvr.	SY5004262
P03	Float Disc	SY3404509	P38	Cvr./Vlv. cvr. gasket	SY5004263
P04	Top Cover	SY3474510	P39	Filter cvr/Cvr. gasket	SY5004268
P05	Valve Cover	SY3474511	P40	Tank/Sump gasket	SY5004373
P06	Air Filter Cover	SY3474519	P41	Elbow	SY9209044
P07	Valve Rod	SY3474521	P42	Solid Plug	SY9209148
P08	Valve Seat In/Outlet	SY3474522	P43	Brass Plug	SY9209420
P09	Main Valve Inlet	SY3474523	P44	Stud	SY9509061
P10	Valve Air Inlet	SY3474524	P45	Stud	SY9509097
P11	Diaphragm	SY3474525	P46	Stud	SY9509104
P12	Float Rod	SY3474526	P47	Stud	SY9509113
P13	Compression Spring	SY3474527	P48	Stud	SY9509119
P14	Float	SY3474547	P49	Stud	SY9509133
P15	Fulcrum Pin	SY3564037	P50	Nut	SY9509652
P16	Valve support Pin	SY3564038	P51	Nut	SY9509653
P17	Air Filter Element	SY3804418	P52	Nut	SY9509654
P18	Valve Seat	SY3564293	P53	Washer	SY9509678
P19	Valve Ball	SY3564294	P54	Steel Washer	SY9509679
P20	Control Vlv adj. seat	SY3564296	P55	Steel Washer	SY9509680
P21	Control Valve	SY3564297	P56	Nylon Washer	SY9509693
P22	Control Vlv ret. sprng	SY3564298	P57	Brass Washer	SY9509694
P23	Distance Piece	SY3564300	P58	Brass Washer	SY9509697
P24	Control Valve Knob	SY3564302	P59	Nylon Washer	SY9509700
P25	Pipe Adaptor	SY3474599	P60	Spring Washer	SY9509808
P26	Instruction plt.	SY3564350	P61	Self Locking Nut	SY9509861
P27	Spring	SY3564354	P62	Self Locking Nut	SY9509864
P28	Cont. Vlv Spindle	SY3564425	P63	Starlock Washer	SY9519256
P29	Air Outlet Valve	SY3614033	P64	Starlock Washer	SY9519260
P30	Fulcrum Bracket	SY3614035	P65	Salterfix Ring	SY9519482
P31	Fulcrum Arm	SY3614036	P66	Cap Screw	SY9529201
P32	'O' Ring	SY3614043	P67	Brass Washer	SY9509701
P33	Tank Primary	SY3804002	-	Hose - Vacuum	SY3804410
P34	Copper Joint	SY5004075	-	Clamp	SY9519581

<b>Sykes Pumps</b>	Ref.No.SY381-4	Issue Status: seventh
OPERATION & MAINTENANCE INSTRUCTIONS	Page 71 of 87	
STANDARD RANGE TRAILER MOUNTED PUMPS	Issued : 9 July	



**Figure 32** 25cfm Priming Tank Assembly

<b>Sykes Pumps</b>	Ref.No.SY381-4	Issue Status: seventh
OPERATION& MAINTENANCE INSTRUCTIONS	Page 72 of 87	
STANDARD RANGE TRAILER MOUNTED PUMPS	Issued : 9 July	

<b>60 cfm Priming Tank Spare Parts</b>							
<b>Item</b>	<b>Qty</b>	<b>Description</b>	<b>Part No</b>	<b>Item</b>	<b>Qty</b>	<b>Description</b>	<b>Part No</b>
T01	16	Nut M12	SY9509654	T31	1	Gasket	SY5004397
T02	16	Washer M12	SY9509860	T32	6	Washer Spring M12	SY9509808
T03	5	Stud, M12 x 65	SY9509138	T33	6	Stud	SY9509134
T04	1	Top Cover	SY3564291	T35	1	Plug Shouldered	SY9209164
T05	5	Stud, M12 x	SY9509152	T36	1	Valve Seat	SY3564293
T06	1	Valve Cover	SY3564292	T37	1	Ball Valve	SY3564294
T07	1	Elbow	SY9209045	T38	1	Nut M6	SY9509651
T08	1	Pipe Adaptor	SY3734296	T39	1	Screw Cheese Hd	SY9509957
T09	1	Filter Element 3	SY3804418	T40	2	Circlip External 6mm	SY9519482
T10	1	Valve cover	SY5004246	T41	1	Spring Ret.	SY3564298
T11	3	Screw M6 x 20	SY9529201	T42	1	Washer M8	SY9509701
T12	3	Washer M6	SY9509697	T43	1	Spindle - Control	SY3564425
T13	1	Tank cover joint	SY5004245	T44	1	Knob Ball	SY3564302
T14	1	Priming Tank	SY3834039	T45	1	Adjustable Seat	SY3564296
T15	1	Float Rod	SY3834046	T46	1	Valve Control	SY3564297
T16	2	Nut Nyloc M10	SY9529425	T47	1	Distance Piece	SY3564300
T17	1	Washer Nylon	SY9509702	T48	1	Spring	SY3564354
T18	1	Float Disc	SY3404509	T49	1	Pilot Valve	SY3834043
T19	1	Float - Primary	SY3404022	T50	1	Nut Nyloc M4	SY9509668
T20	1	Fulcrum Arm	SY3564036	T51	1	Valve Body Top	SY3834041
T21	2	Washer	SY9519260	T52	1	O-Ring	SY3564043
T22	1	Valve Support	SY3564038	T53	1	Valve Stem	SY3834045
T23	2	Washer	SY9519256	T54	1	Diaphragm	SY3564284
T24	1	Fulcrum Pin	SY3564037	T55	1	Valve Body Bottom	SY3834040
T25	1	Ball Valve Polypropylene	SY1544001	T56	1	Main Valve	SY3834042
T26	1	Fulcrum	SY3564035	T57	1	Main Valve Rod	SY3834044
T27	1	Fulcrum	SY5004157	T58	1	Hose PVC 0.25m	SY3404502
T28	1	Reducing Bush	SY9209074	—	2	Vacuum hose clamp	SY3804409
T29	1	Plug Solid Male	SY9209161	—	1	Vacuum hose	SY3804408
T30	1	Instruction Plate	SY3564350				



<i>Sykes Pumps</i>	Ref.No.SY381-4	Issue Status: seventh
OPERATION & MAINTENANCE INSTRUCTIONS	Page 73 of 87	
STANDARD RANGE TRAILER MOUNTED PUMPS	Issued : 9 July	

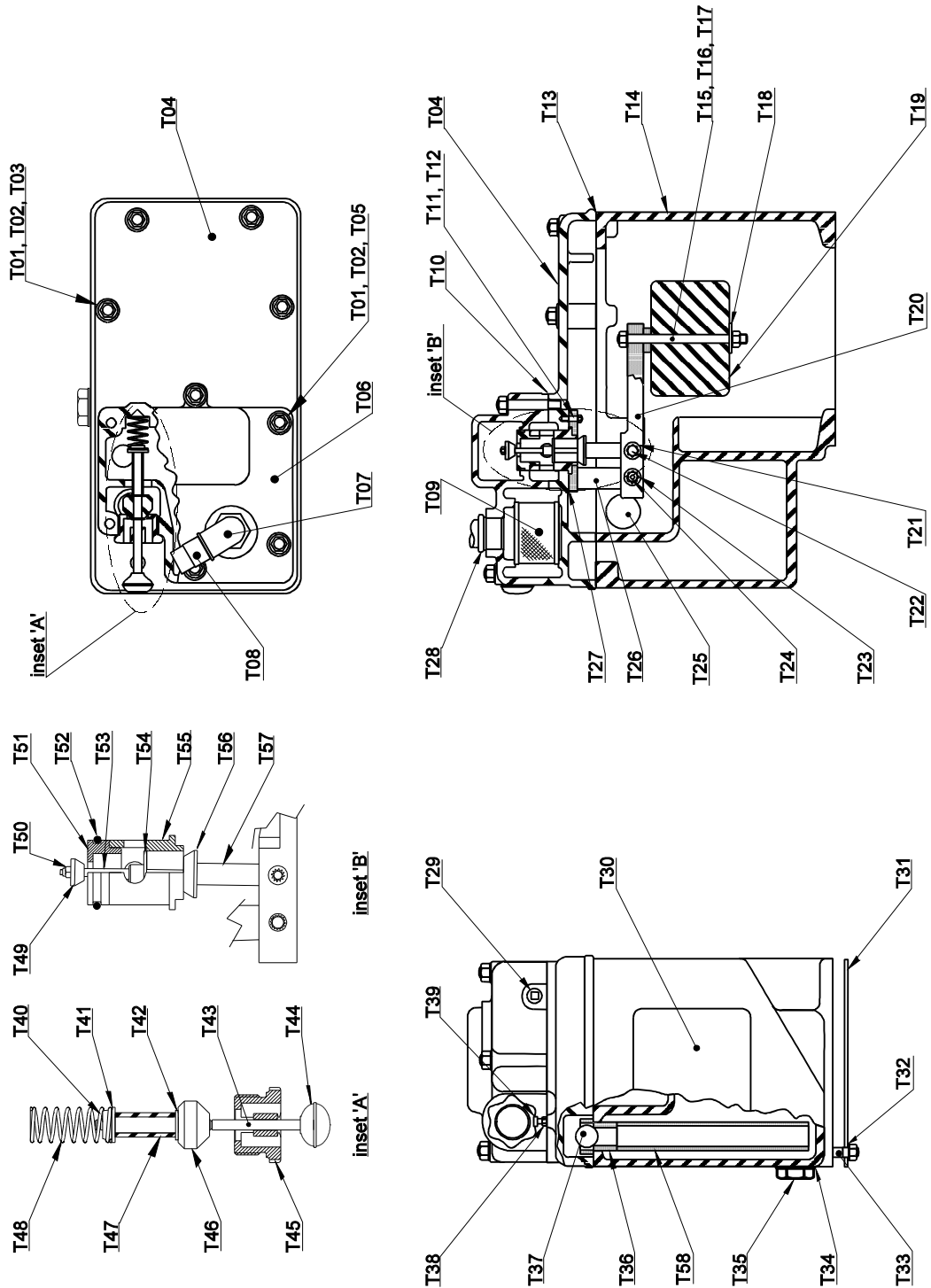
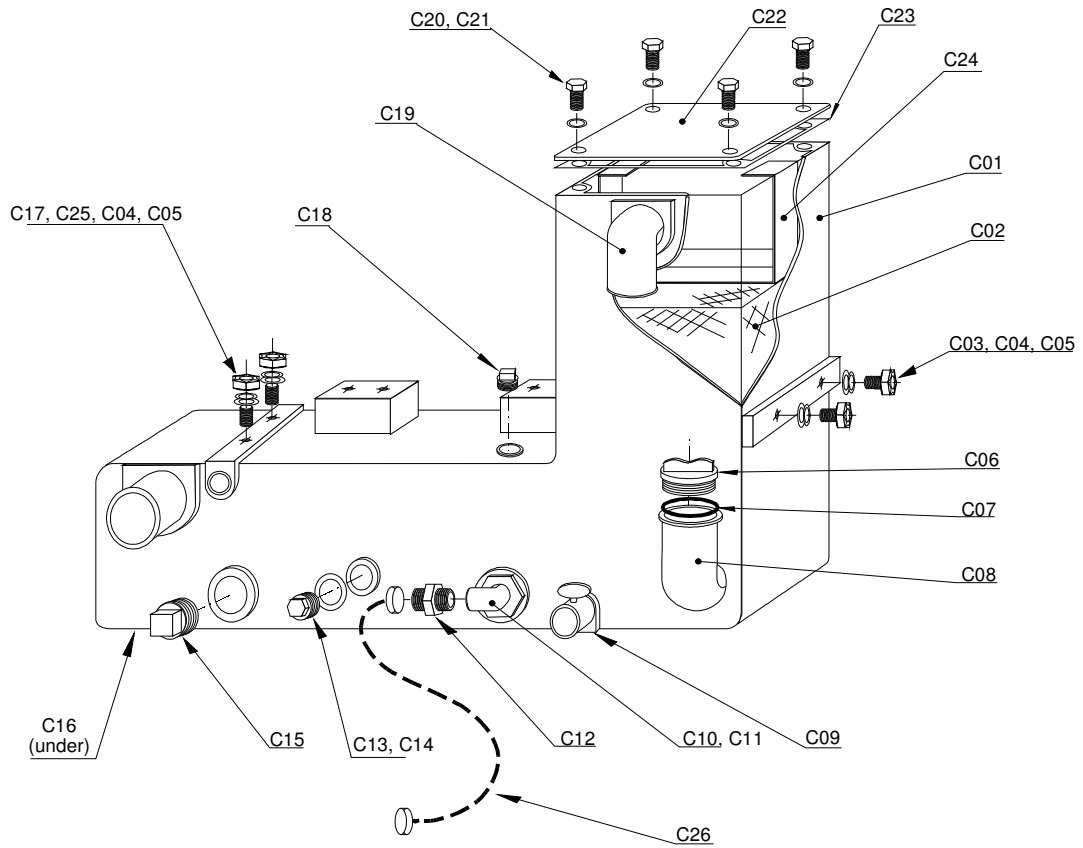

**Figure 33 60 cfm priming tank**

<b>Sykes Pumps</b>	Ref.No.SY381-4	Issue Status: seventh
OPERATION& MAINTENANCE INSTRUCTIONS	Page 74 of 87	
STANDARD RANGE TRAILER MOUNTED PUMPS	Issued : 9 July	

<b>Coalescer Spare Parts</b>			
<b>Item</b>	<b>Qty</b>	<b>Description</b>	<b>Part No</b>
C01	1	coalescer tank	SY3804362
C02	1	coalescent filter	SY6674050
C03	2	tank mounting screw	SY9519140
C04	4	tank mounting washer	SY9509860
C05	4	tank mounting spring washer	SY9509808
C06	1	oil filler cap	SY3844013
C07	1	oil filler cap 'o'-ring	SY3744298
C08	1	oil filler	SY9209047
C09	1	oil drain cock	SY9209730
C10	1	oil filter	SY3824066
C11	1	elbow	SY9209002
C12	1	adaptor - feed hose to vacuum pump	SY9519575
C13	1	oil level sensor blanking plug	SY9209420
C14	1	washer, oil level sensor blanking plug	SY5004075
C15	1	plug	SY9209163
C16	1	oil drain plug	SY9209164
C17	2	tank mounting stud	SY9509133
C18	1	blanking plug, 1/4" BSP	SY9519598
C19	1	air outlet	SY9209045
C20	4	cover securing screw	SY9519075
C21	4	cover mounting spring washer	SY9509805
C22	1	coalescer cover	SY3824065
C23	1	cover joint	SY5004413
C24	1	filter retainer	SY3804357
C25	2	tank mounting nut	SY9509654
C26	1	oil feed hose	SY3804363

<i>Sykes Pumps</i>	Ref.No.SY381-4	Issue Status: seventh
OPERATION& MAINTENANCE INSTRUCTIONS	Page 75 of 87	
STANDARD RANGE TRAILER MOUNTED PUMPS	Issued : 9 July	

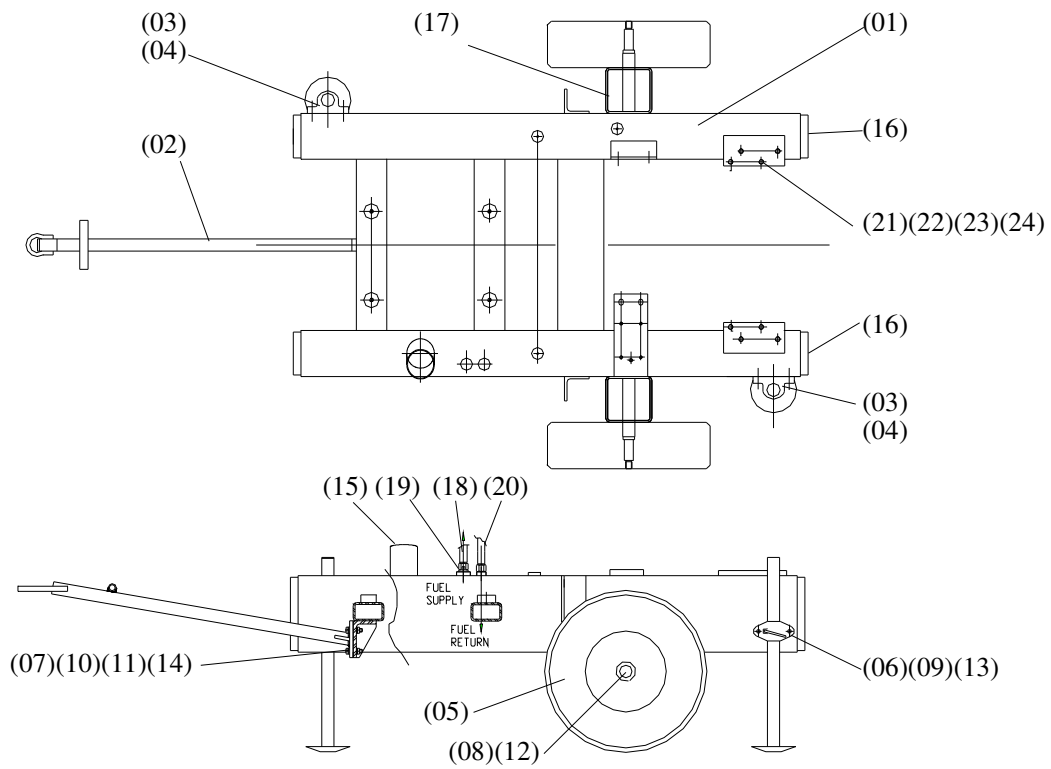

**Figure 34** Coalescer spare parts

<i>Sykes Pumps</i>	Ref.No.SY381-4	Issue Status: seventh
OPERATION& MAINTENANCE INSTRUCTIONS	Page 76 of 87	
STANDARD RANGE TRAILER MOUNTED PUMPS	Issued : 9 July	

<b>2 Wheel Site Trailer Assembly</b>		
<b>Item</b>	<b>Description</b>	<b>GP100M, WP150, GP150M</b>
1	Chassis	SY3803200
2	Bracket - Towing	SY3804059
3	Stand - Trailer Prop	SY9519583
4	Clamp - Trailer Prop	SY9519584
5	Wheel c/w Hub Cap	SY3804058
6	Nut M12	SY9509654
7	Nut M14	SY9519585
8	Nut Nyloc M20	SY9529428
9	Screw M12 x 35	SY9519142
10	Screw M14 x 40	SY9519587
11	Washer M14	SY9519588
12	Washer M20	SY9509684
13	Washer Spring M12	SY9509808
14	Washer Spring M14	SY9519589
15	Filler Cap	SY3354234
16	Plug	SY9519590
17	Axle Box Complete Assy	SY3804251
18	Fuel Line (Feed)	SY3354064
19	Adaptor Standpipe	SY3804057
20	Fuel Line (Return)	SY3354065
21	Stud M16	SY9509216
22	Nut M16	SY9509656
23	Washer Flat M16	SY9509682
24	Washer Spring M16	SY9509810

<i>Sykes Pumps</i>	Ref.No.SY381-4	Issue Status: seventh
OPERATION& MAINTENANCE INSTRUCTIONS	Page 77 of 87	
STANDARD RANGE TRAILER MOUNTED PUMPS	Issued : 9 July	

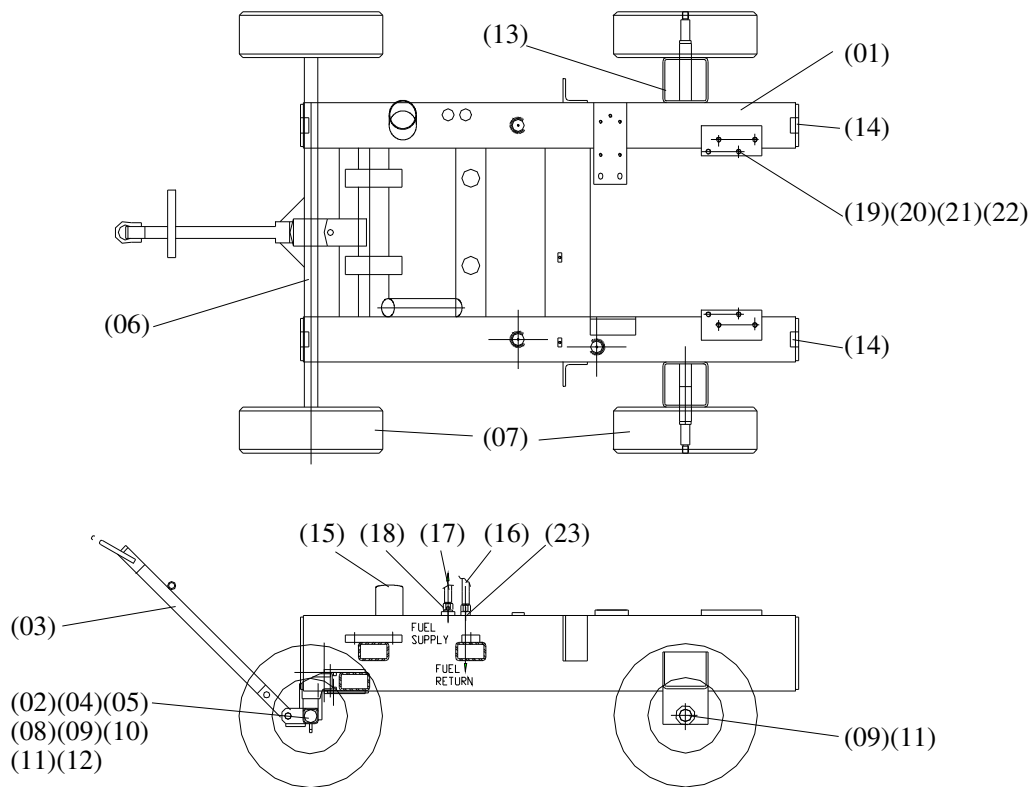

**Figure 35** Two wheel site trailer

<b>Sykes Pumps</b>	Ref.No.SY381-4	Issue Status: seventh
OPERATION& MAINTENANCE INSTRUCTIONS	Page 78 of 87	
STANDARD RANGE TRAILER MOUNTED PUMPS	Issued : 9 July	

<b>4 Wheel Site Trailer Assembly</b>			
<b>Item</b>	<b>Description</b>	<b>GP100M, WP150, GP150M (x60 &amp; x25cfm)</b>	<b>GP200 (x25 &amp; x60cfm)</b>
1	Chassis	SY3803208	SY3844101
2	Swivel - Front Axle	SY3804253	SY3804253
3	Tow Bar	SY3804254-1	SY3804254-1
4	Pin - Swing	SY3804262	SY3804262
5	Pin - Swivel	SY3804263	SY3804263
6	Axle - Front	SY3814144	SY3814144
7	Wheel c/w Hub	SY3814228	SY3814228
8	Bolt M20 x 110	SY9509606	SY9509606
9	Nut Nyloc M20	SY9529428	SY9529428
10	Screw M6 x 12	SY9529322	SY9529322
11	Washer M20	SY9509684	SY9509684
12	Pin Cotter	SY9519593	SY9519593
13	Axle Box Complete	SY3804251	SY3804251
14	Plug	SY9519590	SY9519590
15	Filler Cap	SY3354234	SY3354234
16	Pipe Assy (Return Fuel)	SY3354065	SY3844110
17	Fuel Hose (Feed)	SY3354064	SY3844109
18	Adaptor Standpipe	SY3804057	SY3834015
19	Stud M16	SY9509216	SY9509216
20	Nut M16	SY9509656	SY9509656
21	Washer Flat M16	SY9509682	SY9519594
22	Washer Spring M16	SY9509810	SY9509810
23	Nipple 1/4" x 1/8"	--	SY9519577

<i>Sykes Pumps</i>	Ref.No.SY381-4	Issue Status: seventh
OPERATION& MAINTENANCE INSTRUCTIONS	Page 79 of 87	
STANDARD RANGE TRAILER MOUNTED PUMPS	Issued : 9 July	



**Figure 36** Four wheel site trailer

<b>Sykes Pumps</b>	Ref.No.SY381-4	Issue Status: seventh
OPERATION& MAINTENANCE INSTRUCTIONS	Page 80 of 87	
STANDARD RANGE TRAILER MOUNTED PUMPS	Issued : 9 July	

<b>2 Wheel High Speed Chassis Assembly</b>							
<b>Item</b>	<b>Description</b>	<b>GP100M, WP150, GP150M (x60 &amp; x25cfm)</b>	<b>GP200 (x25&amp;x60c fm)</b>	<b>Item</b>	<b>Description</b>	<b>GP100M, WP150, GP150M (x60 &amp; x25cfm)</b>	<b>GP200 (x25 &amp; x60cfm)</b>
1	Filler Cap	SY3354234	SY3354234	26	Plated Chain	SY9519571	SY9519571
2	Standpipe	SY3804057	SY3804057	27	Split Ring	SY9519596	SY9519596
3	Fuel Hose	SY3354064	SY9519595	28	Wheel Assy	SY3834032	SY3814163
4	Fuel Hose	SY3354065	SY3804065	29	Washer Taper	SY9019307	SY9519567
5	Plug 2"BSPT	SY9519590	SY9519590	30	Coupling	SY3964387	SY3964387
6	Chassis	SY3834201	PBCH2143	31	Compensator	SY9519572	SY9519572
7	'A' Frame	SY3834202	SY3834202	32	Compensator	SY9519573	SY9519573
8	Beam Axle	SY3814162	SY381416	33	Brake Rod	SY9519579	SY9519579
9	Bolt Hex M12x70	SY9509555	SY9509555	34	Jockey Wheel	SY3964386	SY3964386
10	Bolt Hex M12x40	SY9519599	SY9519599	35	Nut Nyloc M12	SY9509866	SY9509866
11	Nut Nyloc M12	SY9509866	SY9509866	36	Nut M16	SY9509656	SY9509656
12	Screw M10	SY9519121	SY9519121	37	Washer M16	SY9509682	SY9509682
13	Washer M10	SY9509679	SY9509679	38	Stud M16	SY9509216	SY9509216
14	Nut Hex M10	SY9509653	SY9509653				
15	Screw M16	SY9519160	SY9519160				
16	Washer M16	SY9509682	SY9509682				
17	Propstand	SY9519583	SY9519583				
18	Clamp Prop	SY9519584	SY9519584				
19	Screw M10	SY9519121	SY9519121				
20	Bracket Mud	SY3834033	SY3834033				
21	Screw M8	SY9519095	SY9519095				
22	Washer M8	SY9509678	SY9509678				
23	Mud Guard	SY3834034	SY3834034				
24	Lighting Board	SY3814167	SY3814167				
25	'R' Clips	SY9519520	SY9519520				



<i>Sykes Pumps</i>	Ref.No.SY381-4	Issue Status: seventh
OPERATION& MAINTENANCE INSTRUCTIONS	Page 81 of 87	
STANDARD RANGE TRAILER MOUNTED PUMPS	Issued : 9 July	

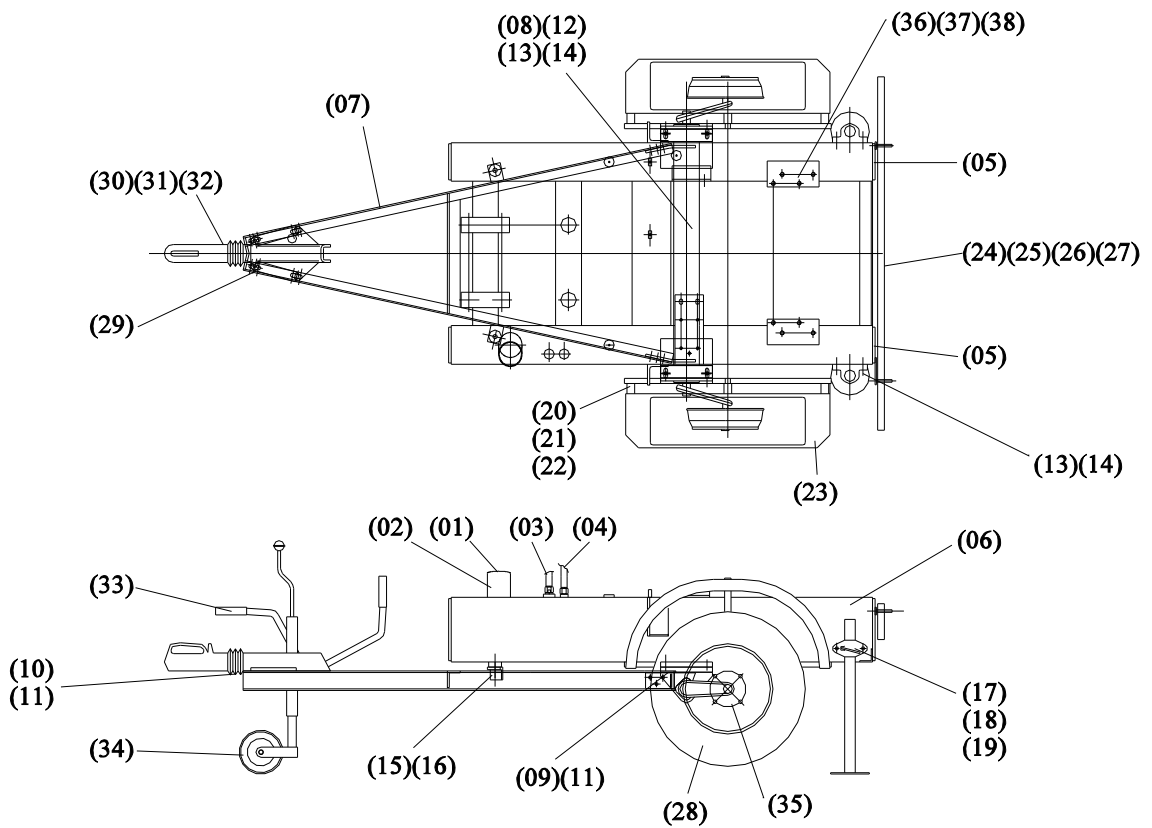

**Figure 37** Two wheel high speed trailer

<i>Sykes Pumps</i>	Ref.No.SY381-4	Issue Status: seventh
OPERATION& MAINTENANCE INSTRUCTIONS	Page 82 of 87	
STANDARD RANGE TRAILER MOUNTED PUMPS	Issued : 9 July	

<b>Sump/Tee Assembly</b>				
<b>Item</b>	<b>Description</b>	<b>GP100M</b>	<b>GP150M &amp; WP150</b>	<b>GP200</b>
1	Pipe Adaptor	SY3734296	SY3734296	SY3734296
2	Suction Cover - Cardboard	SY3804075	SY3404678	---
3 *	Tee Piece/Sump	SY3814001	SY3834038	SY3844031
4	Joint	SY5004121	SY5004106	SY5004113
5	Elbow	SY9209006	SY9209006	SY9209006
6	Nipple	SY3734297	SY3734297	SY3734297
7	Nipple - Hex	SY3734297	SY3734297	SY3734297
8	Plug	SY9209162	SY9209162	SY9209162
9	Valve - Check Brass	SY3734299	SY3734299	SY3734299

\* = Options Available (See Page )

<i>Sykes Pumps</i>	Ref.No.SY381-4	Issue Status: seventh
OPERATION& MAINTENANCE INSTRUCTIONS	Page 83 of 87	
STANDARD RANGE TRAILER MOUNTED PUMPS	Issued : 9 July	

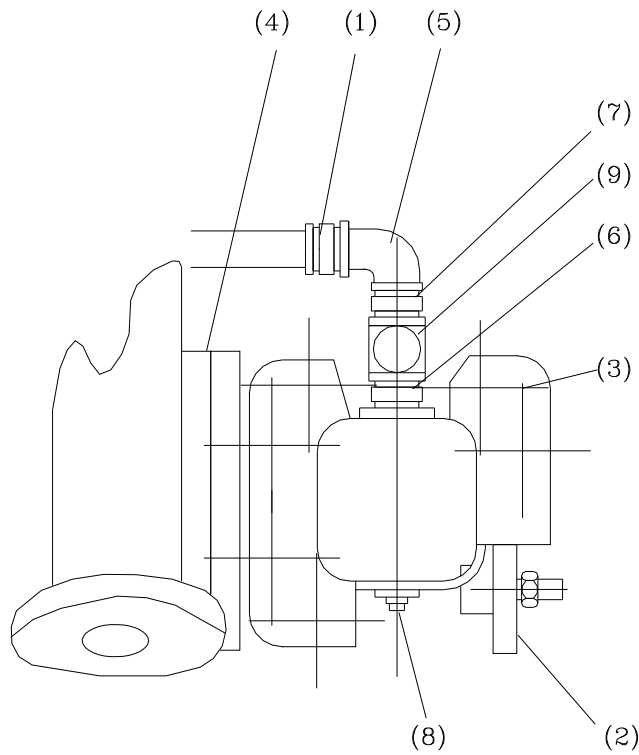

**Figure 38** 10/25 CFM Sump/Tee piece & Fittings Assembly

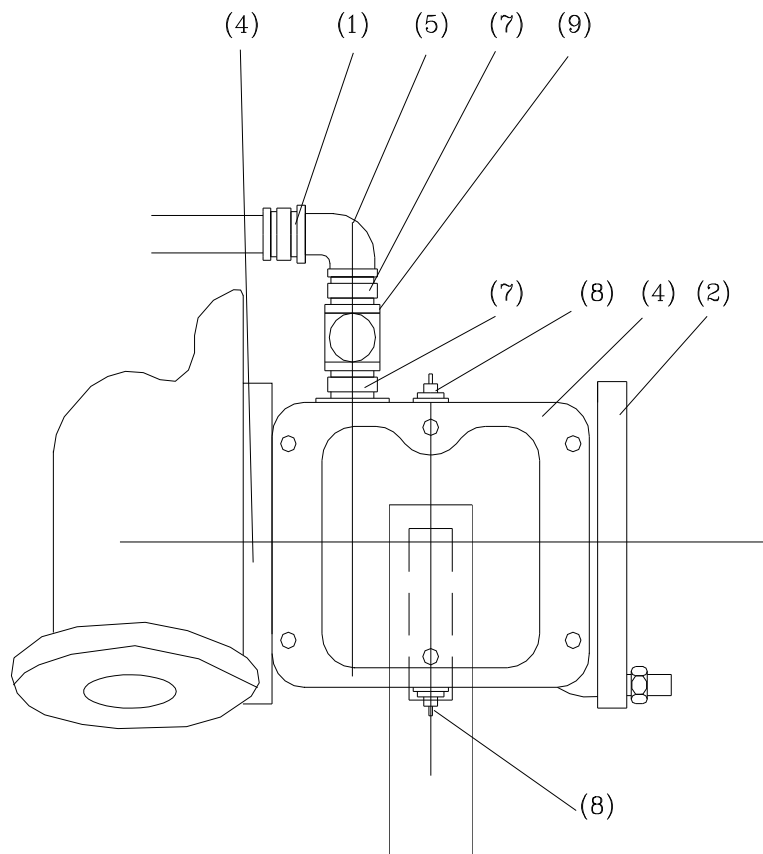
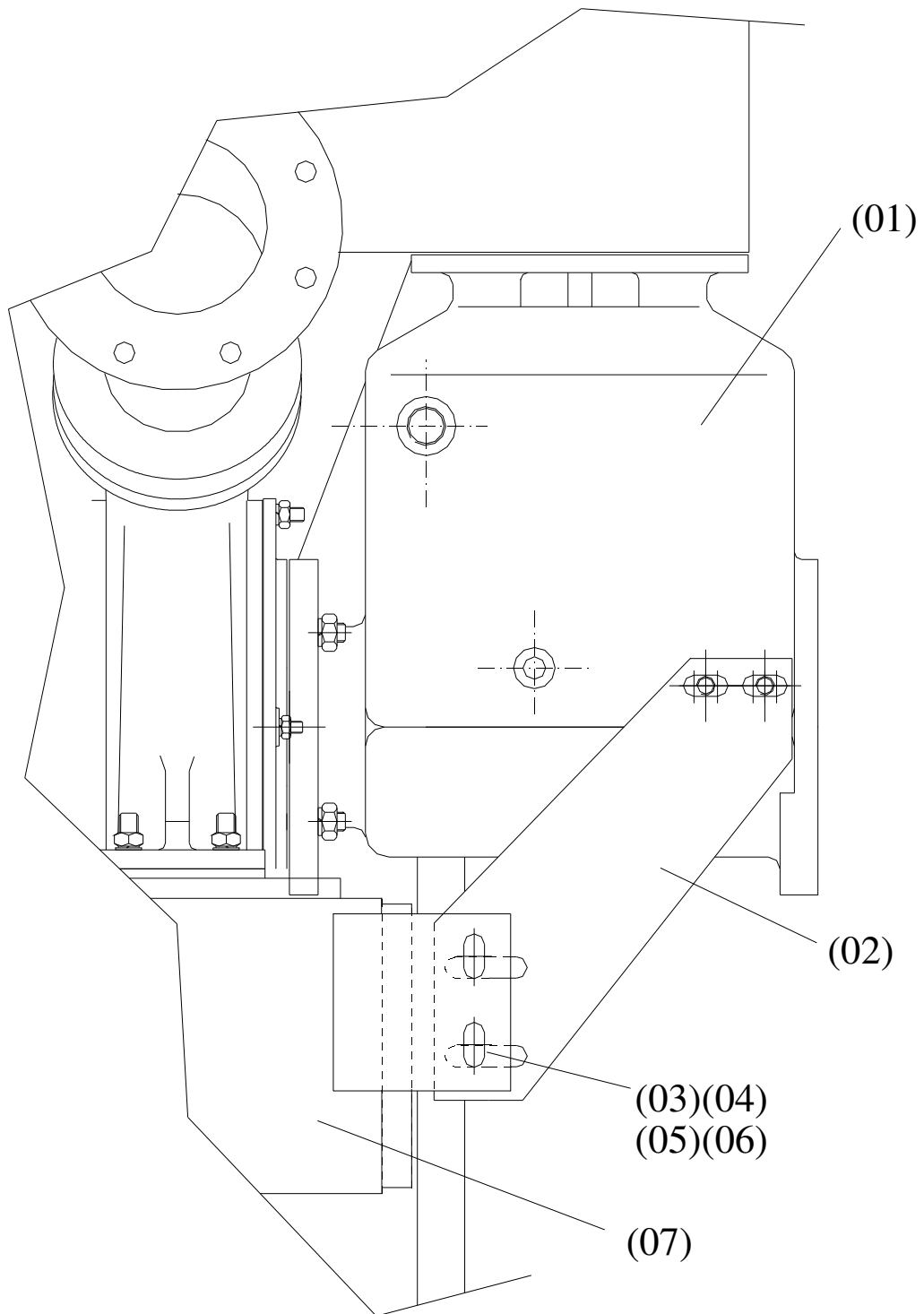

**Figure 39** 60 CFM Sump/Tee piece & Fittings Assembly

<i>Sykes Pumps</i>	Ref.No.SY381-4	Issue Status: seventh
OPERATION& MAINTENANCE INSTRUCTIONS	Page 84 of 87	
STANDARD RANGE TRAILER MOUNTED PUMPS	Issued : 9 July	

<b>Options for Large Volume Sump</b>		
<b>Item</b>	<b>Description</b>	<b>Part No</b>
1	Sump Tee Univac 150/150	SY3834030
2	Support Bracket Sump Tee	SY3834031
3	Screw Set Hex M16x30	SY9519160
4	Nut M16	SY9509656
5	Washer Flat M16	SY9509682
6	Washer Spring M16	SY9509810
7	Chassis Fabrication	SY3834200

<i>Sykes Pumps</i>	Ref.No.SY381-4	Issue Status: seventh
OPERATION& MAINTENANCE INSTRUCTIONS	Page 85 of 87	
STANDARD RANGE TRAILER MOUNTED PUMPS	Issued : 9 July	



**Figure 40** Large volume sump-tee

<b>Sykes Pumps</b>	Ref.No.SY381-4	Issue Status: seventh
OPERATION& MAINTENANCE INSTRUCTIONS	Page 86 of 87	
STANDARD RANGE TRAILER MOUNTED PUMPS	Issued : 9 July	

<b>Options for Impellers &amp; Wear Plates</b>		
<b>Option</b>	<b>GP150M</b>	<b>GP200</b>
<b>Bronze</b> Impeller Assembly Front Wear Back Wear	SY3834177 SY3834192 SY3834176	
<b>High Solids</b> Impeller Assembly Front Wear Back Wear	SY3834111 SY3744036 SY3744004	SY3844046 SY3744239 SY3744004
<b>Anti-Ragging</b> Impeller Assembly Front Wear Back Wear	SY3834171 SY3744036 SY3834166	
<b>Torque Flow</b> Impeller Assembly Back Wear Front Wear	SY3964100 SY3834166 SY3834191	
<b>Option</b>	<b>GP100M</b>	
<b>Torque Flow</b> Impeller Assembly Front Wear Back Wear	SY3824087 SY3814142 SY3814138	

<i>Sykes Pumps</i>	Ref.No.SY381-4	Issue Status: seventh
OPERATION& MAINTENANCE INSTRUCTIONS	Page 87 of 87	
STANDARD RANGE TRAILER MOUNTED PUMPS	Issued : 9 July	

9

## APPENDICES

---

9.1

### Associated Publications

Documents listed under this section are for reference and relate only to the equipment bearing the model and serial numbers indicated in this manual.

<b>Title</b>	<b>Originator</b>
Engine O&M manual	Engine manufacturer
EC Declaration of Conformity	Sykes